

8-2. SPECIFICATIONS

NOTE: * New specification
(Compared with 1979 SRX440)

A. General

Model	SRX440D
Model: Model (I.B.M. No.) Frame I.D. & starting number Engine I.D. & starting number	* SRX440 ('80) (8K6) * 8K6-015101 * RT439-015101
Dimension: Overall length Overall width (std) Overall height (w/windshield)	* 2.570 mm * 990 mm 935 mm

B. Engine

Description: Engine type Engine model Displacement Bore x Stroke Effective compression ratio Starting system Ignition system Lubrication system	Liquid cooled two stroke, twin cylinders RT439 439 cm ³ 68.5 x 59.6 mm 7.0 : 1 Recoil hand starter C.D.I. * "Autolube" oil injection
Cylinder head: Combustion chamber volume (with spark plug) Compression chamber type	21.0 cm ³ Dome + Squish
Cylinder: Material Bore size	Aluminum cylinder with hard chrome bore 68.5 mm
Piston: Piston skirt clearance (measuring point) Piston pin outside diameter x length	0.065 ~ 0.070 mm (10 mm from piston skirt end) φ20 x 56 mm
Piston ring: Piston ring design (Top) Piston ring design (2nd) Ring end gap (installed) (Top) Ring end gap (installed) (2nd)	Keystone 0.35 ~ 0.55 mm
Small end bearing: Type	Needle bearing
Big end bearing: Type	Needle bearing
Crankshaft: Crankshaft assembly width (A) Crankshaft assembly width (F) Crankshaft deflection (D) Connecting rod big end side clearance (C) Connecting rod small end deflection (P)	178 ± 0.1 mm 60 ⁺⁰ _{-0.05} mm 0.03 mm (D-1) 0.04 mm (D-2) 0.04 mm (D-3) 0.05 mm (D-4) 0.25 ~ 0.75 mm 2.0 mm

<p>Crank pin outside diameter x length Crank pin type Crank bearing type (Left) x q'ty Crank bearing type (Center) x q'ty Crank bearing type (Right) x q'ty Crank oil seal type (Left) x q'ty Crank oil seal type (Center) x q'ty Crank oil seal type (Right) x q'ty</p>	<p>φ24 x 59 mm Solid shaft assembly type with serration #6306 special x 2 pcs. #6206 special x 2 pcs. #6206 special x 2 pcs. FWJ-3278 9.5 x 1 pc. Labyrinth seal x 1 pc. FWJ-3248 10 x 1 pc.</p>																																									
<p>Carburetor: * Type & manufacturer/quantity * I.D. Mark * Main jet (M.J.) * Main air jet (M.A.J.) * Power jet (Pw.J.) * Power air jet (Pw.A.J.) * Pilot jet (P.J.) * Pilot air jet (P.A.J.) * Pilot screw (P.S.) * Starter jet (St.J.) * Float height Idling engine speed</p>																																										
<p>[Jet setting chart]</p> <table border="1"> <thead> <tr> <th rowspan="2">Altitude</th> <th colspan="6">Temperature</th> </tr> <tr> <th>-30°C (-22°F)</th> <th>-20°C (-4°F)</th> <th>-10°C (14°F)</th> <th>0°C (32°F)</th> <th>10°C (50°F)</th> <th>20°C (68°F)</th> </tr> </thead> <tbody> <tr> <td>Sea level</td> <td colspan="2">MJ #260 PJ #85</td> <td colspan="2">MJ #250 PJ #85</td> <td colspan="2">MJ #240 PJ #85</td> </tr> <tr> <td>Up to 1000 m (3000 ft)</td> <td colspan="2">MJ #240 PJ #85</td> <td colspan="2">MJ #230 PJ #85</td> <td colspan="2">MJ #220 PJ #85</td> </tr> <tr> <td>Up to 2000 m (6000 ft)</td> <td colspan="2">MJ #210 PJ #95</td> <td colspan="2">MJ #200 PJ #95</td> <td colspan="2">MJ #190 PJ #95</td> </tr> <tr> <td>Up to 3000 m (10000 ft)</td> <td colspan="2">MJ #180 PJ #105</td> <td colspan="2">MJ #170 PJ #105</td> <td colspan="2">MJ #160 PJ #105</td> </tr> </tbody> </table>		Altitude	Temperature						-30°C (-22°F)	-20°C (-4°F)	-10°C (14°F)	0°C (32°F)	10°C (50°F)	20°C (68°F)	Sea level	MJ #260 PJ #85		MJ #250 PJ #85		MJ #240 PJ #85		Up to 1000 m (3000 ft)	MJ #240 PJ #85		MJ #230 PJ #85		MJ #220 PJ #85		Up to 2000 m (6000 ft)	MJ #210 PJ #95		MJ #200 PJ #95		MJ #190 PJ #95		Up to 3000 m (10000 ft)	MJ #180 PJ #105		MJ #170 PJ #105		MJ #160 PJ #105	
Altitude	Temperature																																									
	-30°C (-22°F)	-20°C (-4°F)	-10°C (14°F)	0°C (32°F)	10°C (50°F)	20°C (68°F)																																				
Sea level	MJ #260 PJ #85		MJ #250 PJ #85		MJ #240 PJ #85																																					
Up to 1000 m (3000 ft)	MJ #240 PJ #85		MJ #230 PJ #85		MJ #220 PJ #85																																					
Up to 2000 m (6000 ft)	MJ #210 PJ #95		MJ #200 PJ #95		MJ #190 PJ #95																																					
Up to 3000 m (10000 ft)	MJ #180 PJ #105		MJ #170 PJ #105		MJ #160 PJ #105																																					
<p>Lubrication: * Autolube pump—Color code * Autolube pump—Minimum stroke * Autolube pump—Maximum stroke * Autolube pump—Reduction ratio * Autolube pump—Output Min./200 strokes * Autolube pump—Output Max./200 strokes</p>	<p>Yellow 0.20 ~ 0.25 mm 1.67 ~ 1.87 mm 1/25 0.95 ~ 1.19 cm³ 7.84 ~ 8.89 cm³</p>																																									

* Autolube pump wire free play * Oil tank capacity Oil grade	23±1 mm at idle 2.5 Liter YAMALUBE 2-cycle
Cooling system: Thermostat Open — Close temperature Capacity (Lift) Bearing type Oil seal type Reduction ratio Antifreeze q'ty in system	60 ~ 65°C 2.8 mm/80°C 6201 Z-C ₃ SD20 37 15 51/44 (1.16 : 1) 2.5 Liter automobile all weather antifreeze Antifreeze 50% Water 50%

C. Drive and track suspension

Transmission: Type Drive ratio Engagement rpm Primary spring: Part No. Color code	V-belt automatic centrifugal engagement 3.5 : 1 ~ 1 : 1 * 3,800 ~ 4,200 r/min * 90501-60579 * Red—Brown
Secondary spring: Part No. Color code Secondary spring pre-load (tsist) Sheave distance Sheave off-set V-belt width and outer line length V-belt wear limit	90508-45286 Yellow 90° (No 3 hole) 270 $\begin{smallmatrix} +0 \\ -3 \end{smallmatrix}$ mm 5.5±0.5 mm 31.5 x 1,099 mm 26 mm (1.02 in)
Track suspension: Type Damper type Spring color code (Front) Spring color code (Rear) Slide runner wear limit Track width Track deflection Length on ground Wheel sprocket material and number of teeth Stopper band length	Slide rail suspension Oil and gas damper * Orange No painted 10 mm 380 mm 25 ~ 30 mm/10 kg 850 mm * Polyethylene 12T * 220 mm (8.67 in) (3rd hole from the bottom)
Secondary drive: Type Reduction ratio Chain pitch x Number of links Free play Chain housing oil quantity Chain housing oil grade	Chain (#35K-3) 18/29 (1 : 1.611) 9.525 mm x 70L 10 $\begin{smallmatrix} +5 \\ -2 \end{smallmatrix}$ mm 320 cm ³ Gear oil API "GL-3" (SAE #75 or 80)
Brake: Type Brake pad thickness Brake pad wear limit Brake cable free play	Floating disc type 13.5 mm 9.5 mm 5 mm

D. Chassis

Frame: Material	Aluminum + Steel
Steering system: Caster (ski column) Camber Ski length x width x thickness Ski stance Ski toe-out Steering linkage type Lock to lock angle (Ski) Lock to lock angle (Steering column)	25° 0° 980 x 120 x 2.0 mm * 870 mm 0 ~ 6 mm Tie-rod Right ski, L: 23° R: 30° Left ski, L: 30° R: 23° Right: 51° Left: 51°
Front suspension: Type Damper type	Leaf spring * Oil and gas damper
Fuel tank: Capacity Fuel grade	* 25 Liter Regular-leaded gasoline with octane rating of over 93

E. Electrical

Ignition system: Type—flywheel magneto (C.D.I. Type) Model/Manufacturer Voltage Pulser coil (charge coil) resistance Charging coil resistance	* F170-54 HITACHI 12V 10Ω at 20°C (Red—White) * 225Ω at 20°C (Brown—Red)
Ignition timing: B.T.D.C.	1.4±0.1 mm
Ignition coil: Model/Manufacturer/Quantity Spark gap Primary winding resistance Secondary winding resistance Diode (Yes or No)	CM60-20/HITACHI/1 pc. 9 mm (300 r/min) 11 mm/3,000 r/min 0.15Ω at 20°C (68°F) 3.6kΩ at 20°C (68°F) No
Spark plug: Type & quality Spark plug gap	* NGK B-9ES x 2 pcs. 0.7 ~ 0.8 mm
Spark plug cap: Type Noise suppressor resistance	Rubber type with noise suppressor 5kΩ at 20°C (68°F)
C.D.I. unit: Model/Manufacturer	* TIA01-32/HITACHI
Lighting system: Lighting output Lighting coil resistance Headlight type Bulb wattage/q'ty Tail/Brake light wattage	12V-100V 0.22Ω at 20°C (68°F) (Yellow—Black) Halogen light * 12V-45/40W x 1 pc. 12V-8W/23W
A.C. regulator: Model/Manufacturer Voltage	TRIZ-24B HITACHI or S8516B TOSHIBA 13.8±0.5V

F. Tightening torque

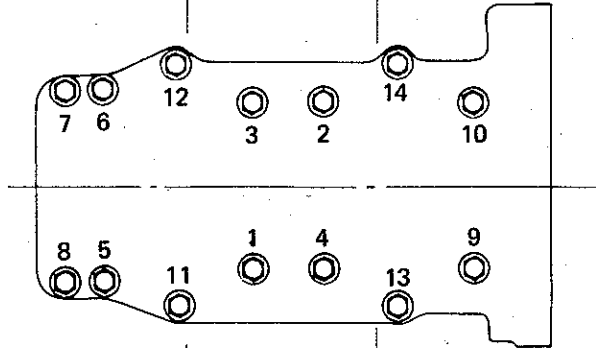
Part to be tightened	Thread size	Tightening torque	Remarks
<p>[Engine]</p> <p>Spark plug Cylinder head Cylinder head Flywheel magneto Crankcase upper and lower</p> <p>Tightening sequence</p> 	<p>M14 P1.25 M8 P1.25 M10 P1.25 M16 P1.0 M8 P1.25</p>	<p>28 Nm (2.8 m-kg) 25 Nm (2.5 m-kg) 30 Nm (3.0 m-kg) 73 Nm (7.3 m-kg) First: 10 Nm (1.0 m-kg) final: 22 Nm (2.2 m-kg)</p>	
<p>Starter pulley Crankcase and engine bracket</p>	<p>M8 P1.25 M10 P1.25</p>	<p>15 Nm (1.5 m-kg) 40 Nm (4.0 m-kg)</p>	
<p>[Drive and track suspension]</p> <p>Primary sliding sheave and cap Installation of primary sheave</p> <p>Installation of secondary sheave Bearing housing Secondary shaft and bearing collar Brake caliper and housing chain Installation of drive chain sprocket Installation of driven chain sprocket Chain housing and frame Installation of front axle L.H. Front axle housing and frame Wheel sprocket and front axle Front pivot shaft Rear pivot shaft Guide wheel shaft Sliding runner</p>	<p>M6 P1.0 UNF 1/2"</p> <p>M10 P1.25 M10 P1.25 Socket screw M10 P1.25 M10 P1.25 M10 P1.25 M8 P1.25 M22 P1.0 M8 P1.25 M10 P1.25 M10 P1.25 M12 P1.25 M8 P1.25</p>	<p>11 Nm (1.1 m-kg) Initial: 120 Nm (12 m-kg) Loosen once and retighten: 65 Nm (6.5 m-kg) 50 Nm (5.0 m-kg) 65 Nm (6.5 m-kg) 6 Nm (0.6 m-kg) 50 Nm (5.0 m-kg) 50 Nm (5.0 m-kg) 50 Nm (5.0 m-kg) 23 Nm (2.3 m-kg) 85 Nm (8.5 m-kg) 23 Nm (2.3 m-kg) 5.5 Nm (0.55 m-kg) 65 Nm (6.5 m-kg) 65 Nm (6.5 m-kg) 80 Nm (8.0 m-kg) 4.5 Nm (0.45 m-kg)</p>	<p>Use motor oil</p> <p>Nut Bolt</p>
<p>[Chassis]</p> <p>Engine mounting nut Ski runner</p> <p>Steering column and gate Steering relay rod adjusting nut Outside arm and ski column Steering lower bracket Installation of steering column 1, 2 Steering relay ass'y</p>	<p>M10 P1.25 M8 P1.25</p> <p>M6 P1.0 M10 P1.25 M10 P1.25 M8 P1.25 M6 P1.0 M10 P1.25</p>	<p>52 Nm (5.2 m-kg) 14 Nm (1.4 m-kg)</p> <p>7.3 Nm (0.73 m-kg) 25 Nm (2.5 m-kg) 40 Nm (4.0 m-kg) 13.7 Nm (1.37 m-kg) 9 Nm (0.9 m-kg) 30 Nm (3.0 m-kg)</p>	<p>Use self-locking nut and LOCK-TITE Use lock washer Use lock washer Use lock washer Use lock washer Use cotter pin</p>

8-3. WIRING DIAGRAM

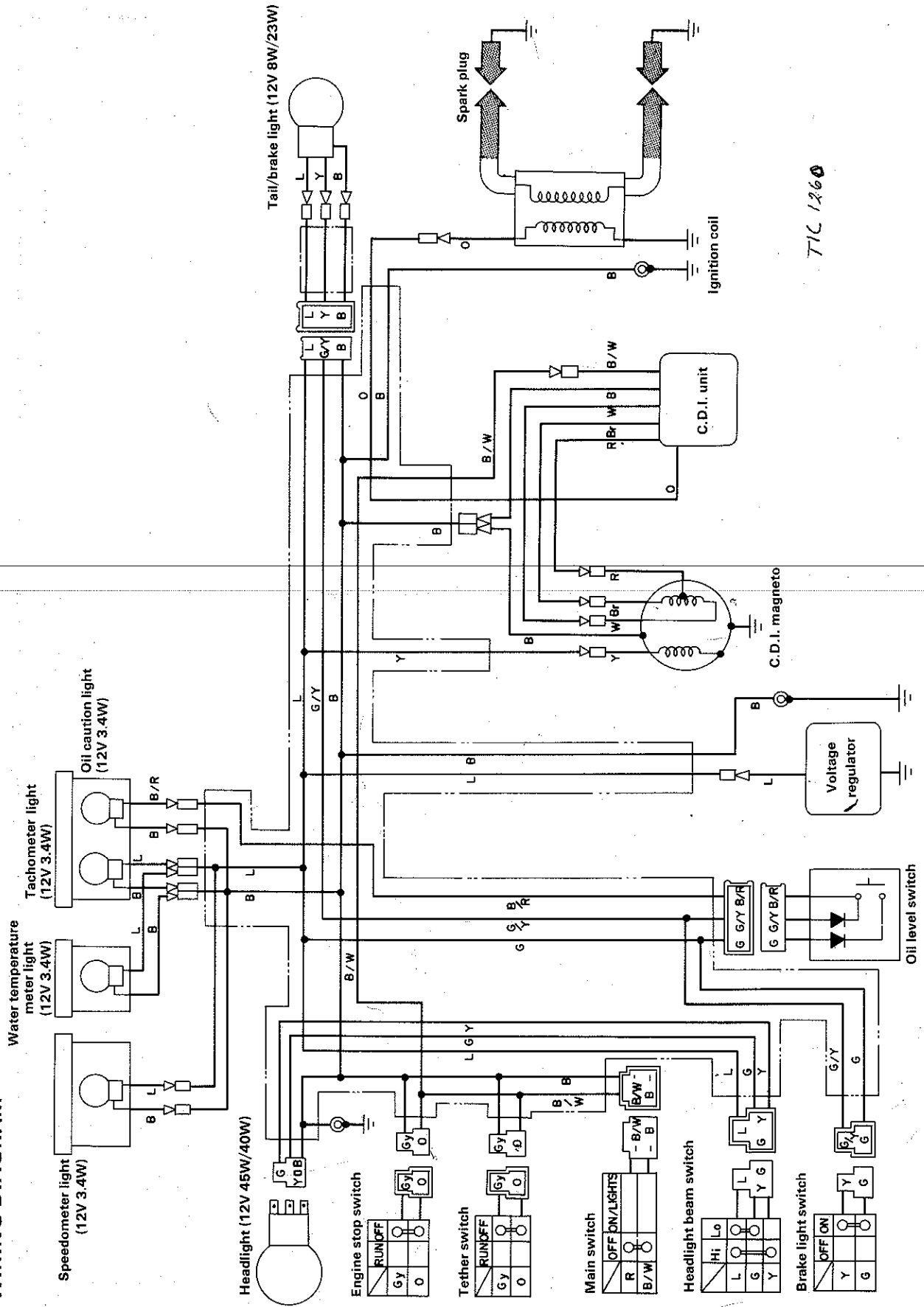

TIC 1260

8-4. WIRE AND PIPE ROUTING DIAGRAM

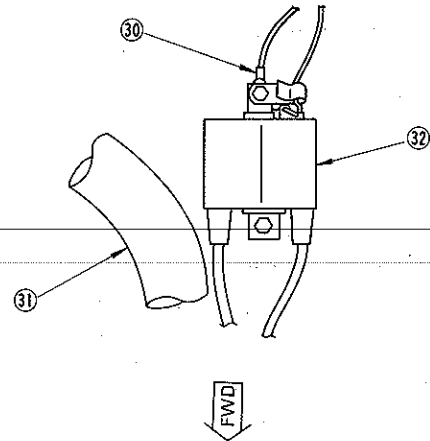
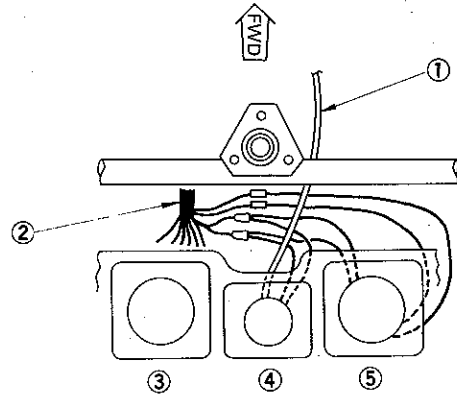
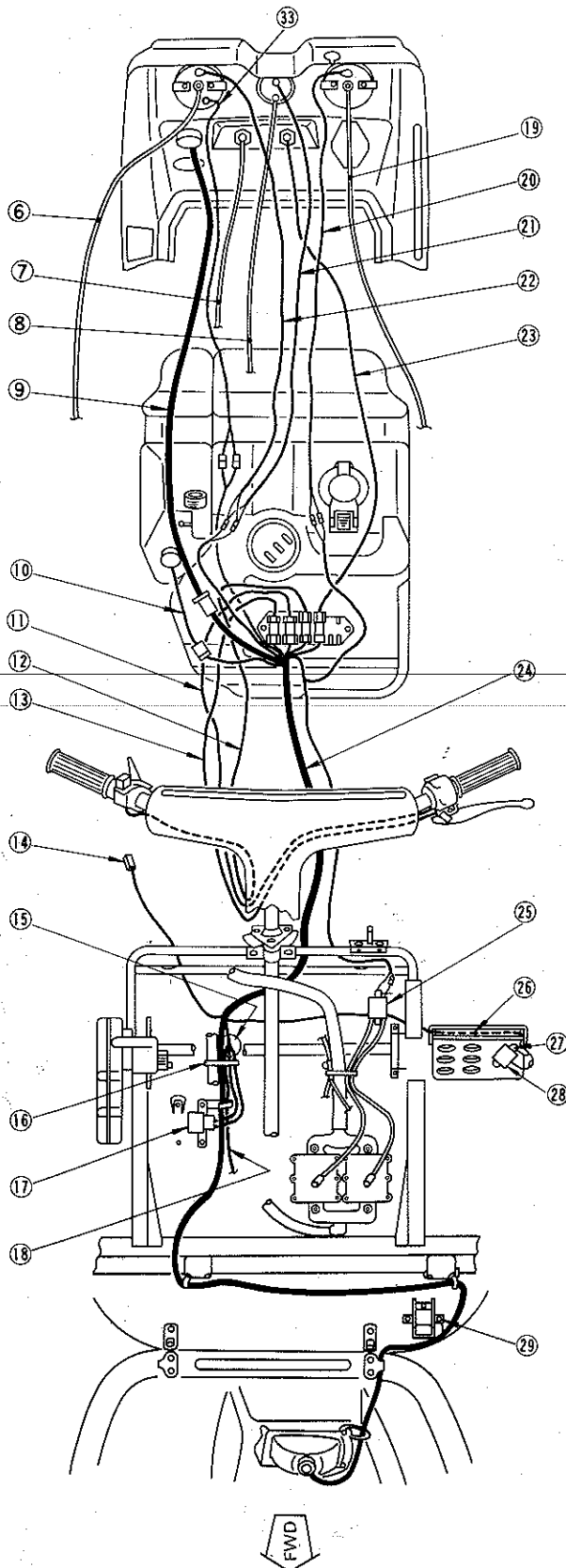

1. Water temperature meter cable
2. Wire harness assembly
3. Speedometer
4. Water temperature meter
5. Tachometer
6. Tachometer cable (To water pump driven gear)
7. Starter cable
8. Water temperature meter cable
9. Main switch lead wire
10. Oil level gauge lead wire
11. Headlight beam switch lead wire
12. Engine stop switch lead wire
13. Brake light switch lead wire
14. Connect the taillight lead wire. (Route the lead wire under the oil tank)
15. Connecting point of C.D.I. unit lead wire, C.D.I. magneto lead wire, wire harness and other lead wire.
16. Band (Clamp the water hose, wire harness, C.D.I. magneto lead wire, and C.D.I. unit lead wires.)
17. C.D.I. unit.
18. C.D.I. magneto lead wire
19. Speedometer cable
20. Speedometer lead wire
21. Water temperature meter lead wire
22. Tachometer lead wire
23. Tether switch lead wire
24. Wire harness assembly
25. Ignition coil
26. Voltage regulator lead wire
27. Ground lead wire (Tighten the lead wire end, together with regulator securing bolt.)
28. Voltage regulator
29. Ground lead wire (Tighten the lead wire end, together with V-belt under side holder.)
30. Ground lead wire
31. Water hose
32. Ignition coil
33. Oil caution light lead wire

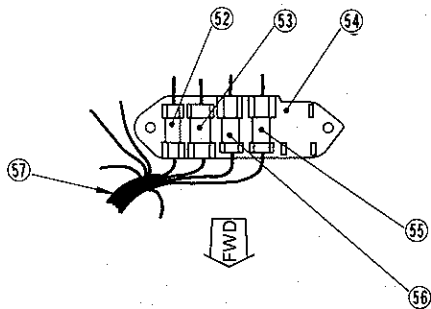
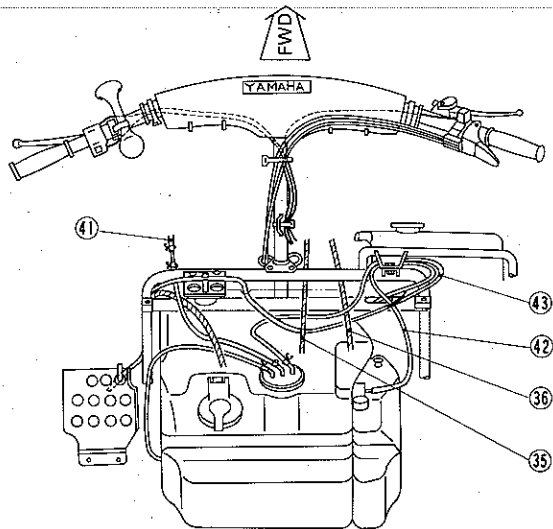
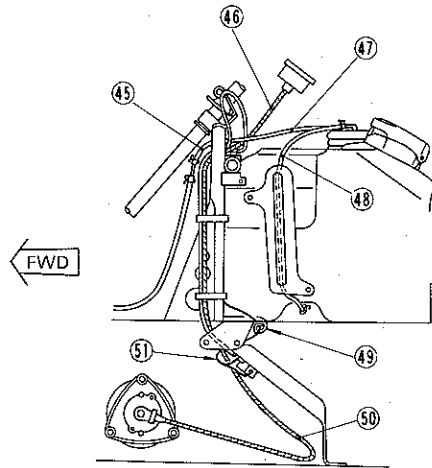
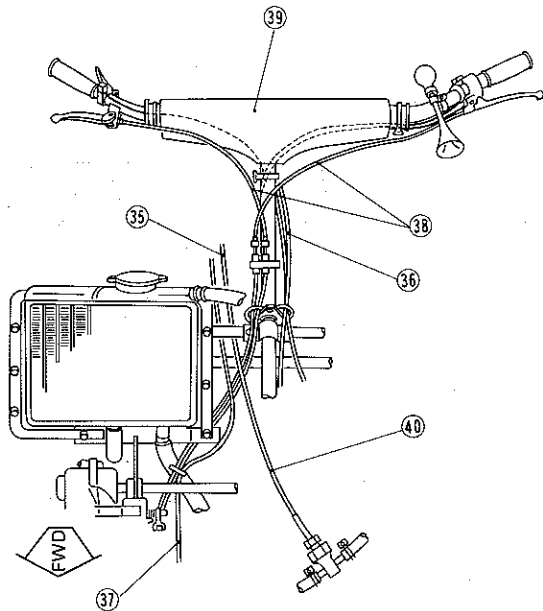

- 34. Throttle cable
- 35. Water temperature meter cable
- 36. Tachometer cable
- 37. To water pump driven gear
- 38. Brake cable
- 39. Steering pad
- 40. Route the cable over the intake silencer.
- 41. Fuel pipe
- 42. Oil tank breather pipe
- 43. Fuel tank breather pipe
- 44. To fuel pump
- 45. Fuel pipe
- 46. Speedometer cable
- 47. Fuel pipe
- 48. Fuel level pipe
- 49. Wire harness protector
- 50. Bend cable at large curve
- 51. Voltage regulator lead wire
- 52. Brake light switch coupler
- 53. Headlight beam switch coupler
- 54. Coupler holder
- 55. Tether switch coupler
- 56. Engine stop switch coupler
- 57. Wire harness

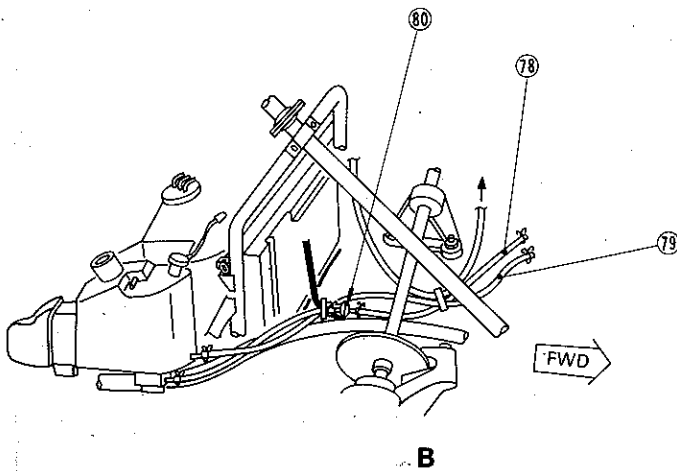
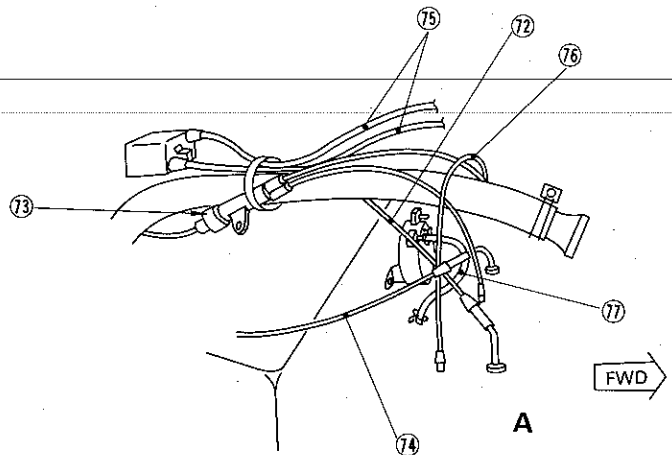
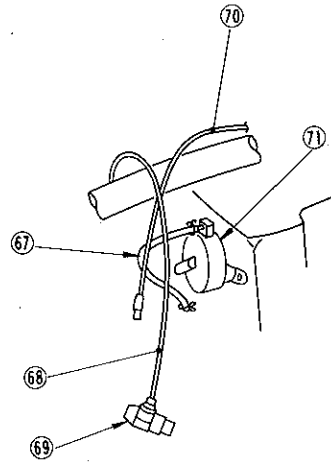
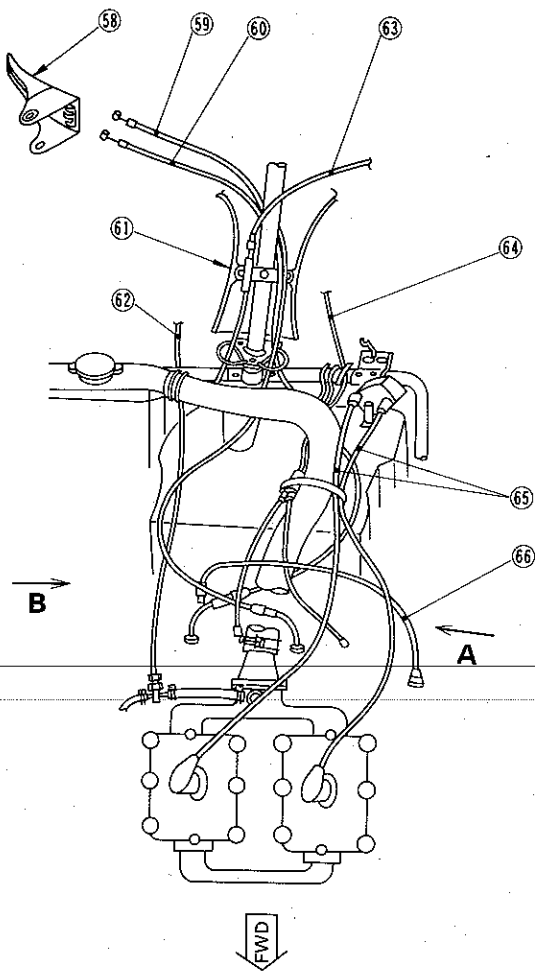

- 58. Throttle lever
- 59. Left carburetor throttle cable (Upper side)
- 60. Right carburetor throttle cable (Lower side)
- 61. Steering pad
- 62. Water temperature meter cable
- 63. Brake cable
- 64. Starter cable
- 65. High tension cord
- 66. Oil pump cable
- 67. Fuel pipe (To left carburetor)
- 68. Oil pump cable
- 69. Oil pump
- 70. Starter cable (for left carburetor)
- 71. Fuel pump
- 72. Throttle cable (for right carburetor)
- 73. Starter cable cylinder
- 74. Throttle cable (for left carburetor)
- 75. High-tension cord
- 76. Oil pump cable
- 77. Fuel pipe (To right carburetor)
- 78. Oil pipe (To upper nozzle of oil pump)
- 79. Oil pipe (To lower nozzle of oil pump)
- 80. Oil filter

— MEMO —