

CHAPTER TWO

PERIODIC MAINTENANCE AND TUNE-UP

To gain the utmost in safety, performance, and useful life from your machine, it is necessary to make periodic inspections and adjustments. It frequently happens that minor problems are found during such inspections that are simple and inexpensive to correct at the time, but which could lead to major problems later.

This chapter includes routine maintenance and inspections as well as complete tune-up procedures for all models. **Table 1** summarizes this important information. Keep detailed records of inspections, adjustments, and tune-ups. Such records can help identify recurring trouble areas as well as ensure that required maintenance and tune-up items are accomplished as recommended by the manufacturer.

INLINE FUEL FILTER

Replace the inline fuel filter at the beginning of each season's operation. Examine the filter periodically as specified in **Table 1** and replace it if there is evidence of fuel line contamination.

FAN BELT TENSION

Check fan belt tension at specified intervals (**Table 1**).

1. Remove the fan cover and recoil starter mechanism.

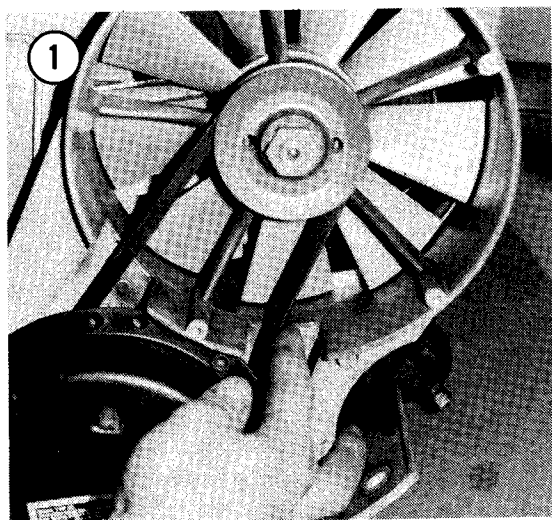

2. Deflect belt with your fingers as shown in **Figure 1**. Examine belt for signs of fraying or deterioration. Adjust belt if deflection is more than $\frac{1}{4}$ in. (6mm) as outlined under *Fan Belt Adjustment*, Chapter Four. Replace belt if necessary.

DRIVE AND DRIVEN PULLEYS

All drive and driven pulleys should be removed, disassembled, cleaned, and inspected for worn parts annually. The majority of work on

Table 1 SCHEDULED MAINTENANCE

| Check the following items at indicated intervals: | Annually | Monthly (or 40 hrs. operation) | Weekly (or 10 hrs. operation) | Daily |
|---|----------|--------------------------------|-------------------------------|-------|
| Windshield | X | X | X | X |
| Condition of skis and steering components | X | X | X | X |
| Track condition and tension | X | X | X | X |
| Throttle control | X | X | X | X |
| Brake | X | X | X | X |
| Emergency stop switch | X | X | X | X |
| Lighting system | X | X | X | X |
| Chaincase oil level | X | X | X | |
| In-line filter for contamination | X | X | X | |
| Drive belt | X | X | X | |
| Carburetor adjustments | X | X | | |
| Ski alignment | X | X | | |
| Fan belt tension | X | X | | |
| Headlight adjustment | X | X | | |
| Ski runner shoes | X | X | | |
| Slide suspension wear bars | X | X | | |
| All components for condition and tightness | X | | | |
| Drive and driven pulleys | X | | | |

these components requires special tools and expertise. Refer to Chapter Seven for work you can perform. Refer all other work to an authorized dealer.

DRIVE BELT

Examine drive belt periodically as specified in Table 1. If belt shows unusual signs of wear, refer to Chapter Three for drive belt analysis and troubleshooting. Replace drive belt if its width is reduced by 1/8 in. (3mm). Refer to Chapter Seven for standard width and drive belt replacement for your model. Drive belts are not interchangeable between different models even though belt width may be the same.

Removal/Installation

Refer to Figure 2 for this procedure.

1. Tilt cab and remove pulley guard.

2. Twist and push sliding half of driven pulley to open pulley.
3. Hold pulley in open position and slip drive belt off of driven pulley and then off the drive pulley.

CAUTION

Do not pry belt off over pulleys or belt and/or pulleys may be damaged.

4. Installation is the reverse of these steps. Check drive belt tension as outlined in Chapter Seven.

BRAKES

Check brake operation as scheduled in Table 1. Brakes are operating properly if the track is locked when the brake control lever is the specified distance from handlebar grip. If brake control lever movement is excessive, perform brake adjustment.

Brake Adjustment (Bombardier Self-Adjusting Disc)

1. Rotate cable, adjusting nuts until no free play exists between brake lever and brake housing on handlebar.
2. Measure gap between brake lever and brake caliper. Gap should be $2 \pm \frac{1}{8}$ in. (50 ± 3 mm) on floating caliper type and $1\frac{1}{2} \pm \frac{1}{8}$ in. (38 ± 3 mm) on floating disc type (**Figure 3**). On Blizzard 5500 models, gap should be $2\frac{1}{4} \pm \frac{1}{8}$ in. (57 ± 3 mm). Rotate adjuster nut until specified dimension is achieved.

NOTE: On floating caliper type it may be necessary to move brake light switch support to achieve specified gap.

3. Check operation of brake light and loosen and adjust light switch locknuts if necessary (**Figure 4**).

Brake Adjustment (Except Bombardier Self-Adjusting Disc)

1. Firmly apply brake and measure distance between brake control lever and handlebar grip. Distance should be as follows:
 - a. Pivot brake and 1970-1971 drum brakes, $\frac{1}{4}$ in. (6.4mm).
 - b. All drum and disc except self-adjusting disc, 1 in. (25mm).
 - c. Self-adjusting disc, $\frac{1}{2}$ in. (13mm).
2. If distance between brake lever and handlebar grip is excessive, loosen locknuts on brake cable and adjust cable for specified dimension (**Figure 5**).
3. Tighten brake cable locknuts and recheck. Readjust if necessary.
4. Check operation of brake light and loosen and adjust light switch locknuts if necessary (**Figure 6**).

Hydraulic Disc Brake Bleeding

Check that fluid level is within $\frac{1}{8}$ in. (3.2mm) from the top of master cylinder reservoir. Use only brake fluid specified SAE 70R3, DOT 3, or DOT 4 for automotive disc brake application.

If brake work has been performed or if brake operation is "spongy," bleeding may be necessary to expel any air from the system.

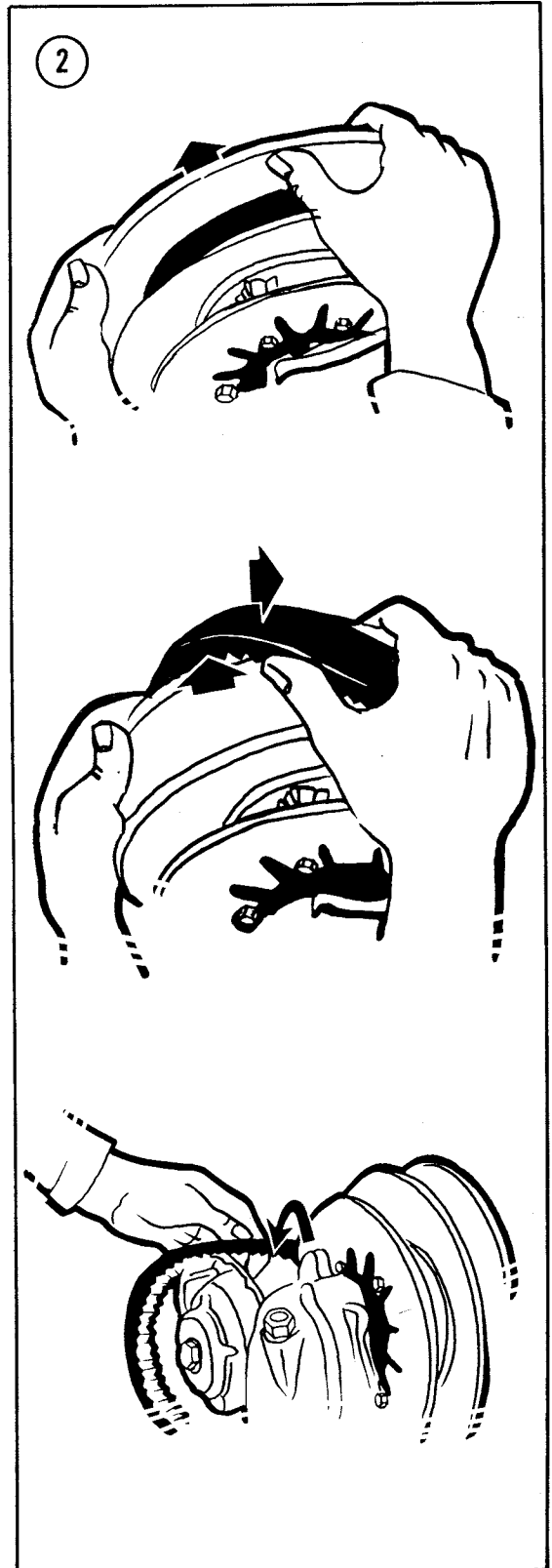

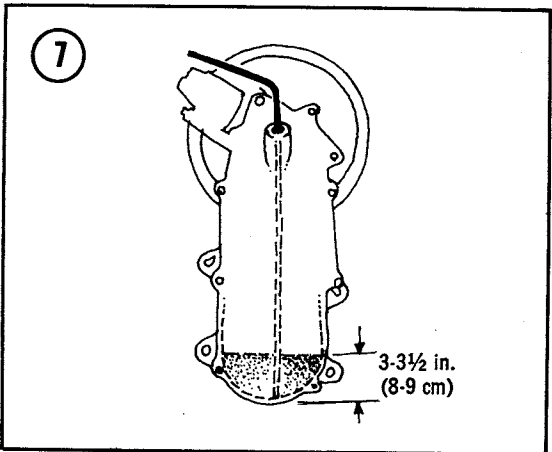
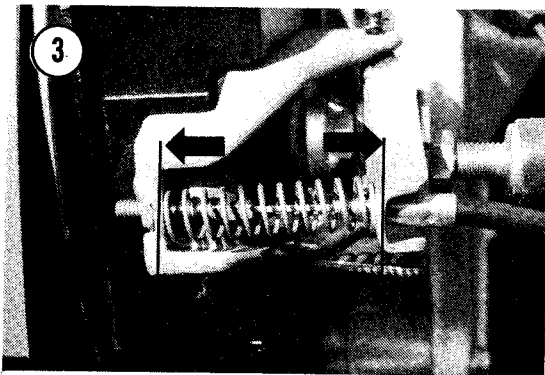

NOTE: During bleeding operation, be sure master cylinder reservoir is kept topped up to the specified level. If level is allowed to drop too low, air may be ingested, requiring complete rebleeding.

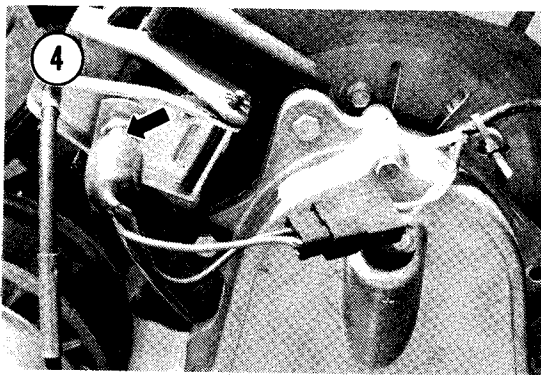

1. Connect a plastic or rubber hose to brake bleeder nipple. Place other end of hose in a container with a few inches of clean brake fluid. Keep hose end below the level of the brake fluid.

2. Open brake bleed valve slightly.

3. Operate brake lever and note air bubbles released in jar. Continue operating brakes until all air is expelled. Be sure to keep master cylinder level topped off.

4. After all air has been expelled, close bleeder valve while slowly squeezing brake lever. Check all connections for leaks and remove bleeder hose.

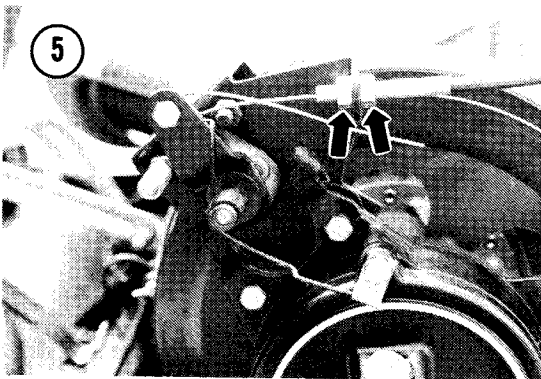

CAUTION

Do not use brake fluid from bleed jar to top off reservoir as the fluid is already aerated.

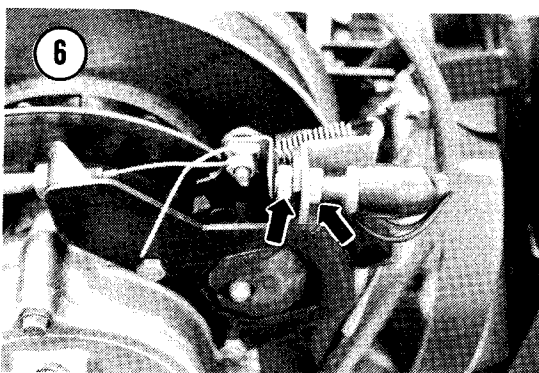

CHAINCASE OIL LEVEL

Check level of chaincase oil at intervals specified in Table 1 earlier in this chapter.

NOTE: On models where oil level is difficult to see, because of tool box, use a long piece of stiff wire as a dipstick and measure oil level through filler hole (Figure 7). Ensure that dipstick touches bottom of chaincase. Oil level should be 3-3/4 in. (8-9 cm).

On machines with pressed steel chaincase and aluminum chaincase (without external tension adjuster) oil level should be flush with indicator level or plug (**Figure 8**).

On models with aluminum chaincase with external tension adjuster, total quantity of oil is 6 oz. (180cc).

On later model Blizzards oil level should be to bottom of the oil level opening as shown in **Figure 9**.

Top off oil level if necessary with Ski-Doo chaincase oil or equivalent (SAE 30).

Use a syringe or oil suction device to remove old oil when changing oil for machine storage preparation.

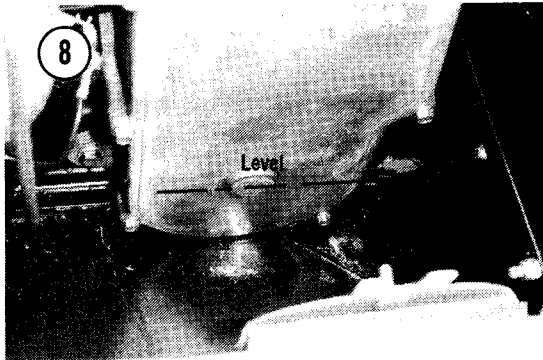

Rotary Valve Oil Reservoir

Check level of oil in reservoir frequently on rotary valve models. Do not allow oil level to fall below line on reservoir as shown in **Figure 10**. Top off reservoir with Castrol Injector Oil.

Liquid Coolant Level

Coolant level should be 1 in. (25mm) below filler neck of coolant tank. Start engine and run at least one minute after thermostat opens; 110°F (43°C). Stop engine and check coolant level. Top up if necessary with a 60% antifreeze and 40% water mixture.

WARNING

Always remove pressure cap from a hot engine very carefully with a rag over the cap. Unscrew the cap to the first step only, until all pressure is released or serious burns from hot coolant may result.

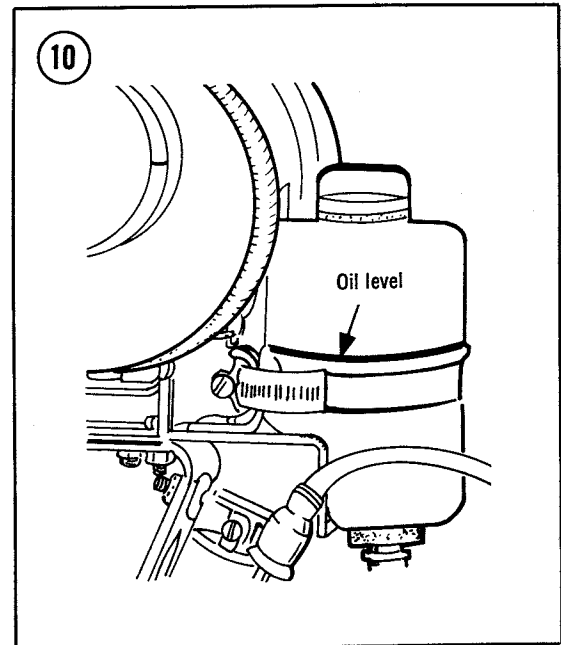
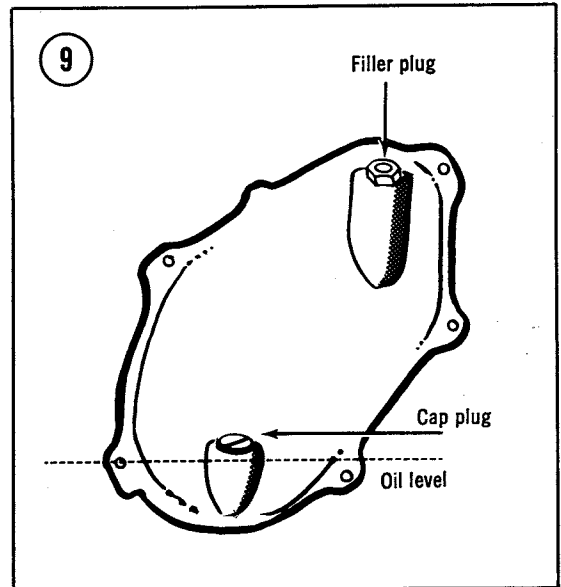

TRACK TENSION ADJUSTMENT

Proper track tension is very important to obtain maximum life and service from the track. Check for track "ratcheting" and proper tension at intervals specified in **Table 1** earlier in this chapter.

Track "ratcheting" occurs if track is too loose and drive lugs on the track slip over the cogs on the drive wheel.

Table 2 TRACK TENSION ADJUSTMENT SPECIFICATIONS

| Suspension | Adjustment |
|--|-------------------------|
| Bogie wheel suspension | |
| 1970-1971 models (measured from bottom edge of center bogie wheel to inside edge of track) | 2½-3 in. (6.4-7.6 cm) |
| All other models (measured from top inside edge of track to bottom of foot board) | |
| Elan | 1¼-1½ in. (3.2-3.8 cm) |
| Olympique | 2⅝-2¾ in. (5.4-6.0 cm) |
| Slide suspension | |
| All models 1970-1973 (measure from foot board to inside of track) | 5¾-6 in. (14.6-15.2 cm) |
| 1974 and later (measure between bottom of slider shoe and inside of track) | |
| Ground leveller suspension | ½-⅝ in. (1.3-1.6 cm) |
| High performance suspension | ⅝ in. (1.6 cm) |
| Torque reaction suspension | |
| All Olympique; all 1978-1979 models | ½ in. (1.3 cm) |
| All other models | ¾ in. (1.9 cm) |

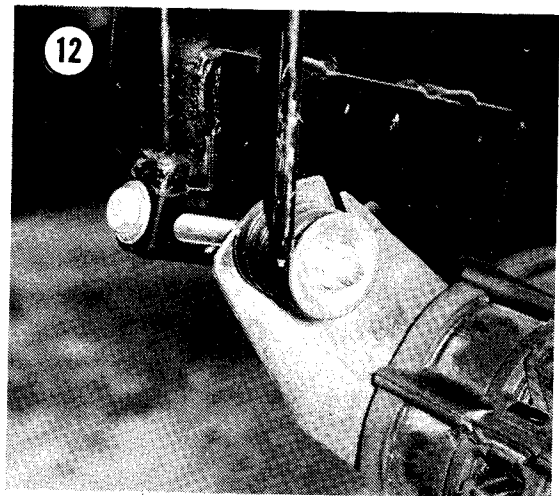
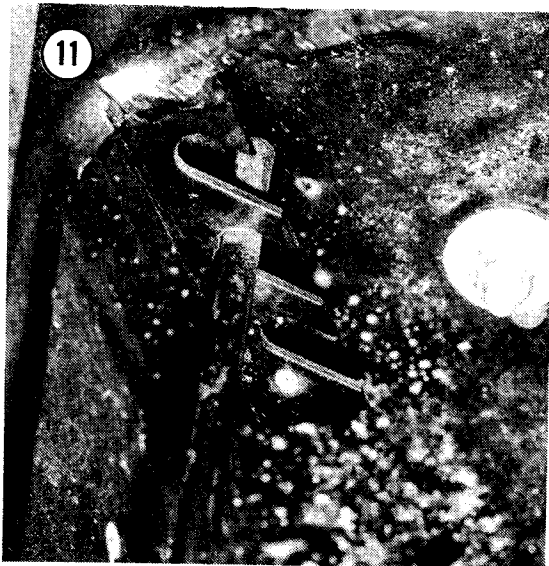

(Figure 11). Do not attempt to correct track tension by changing position of link plate springs.

Bogie Suspension

1. Raise rear of snowmobile; block securely.
2. Measure track tension as specified in Table 2.
3. If track tension is incorrect perform the following:

NOTE: On models with 3-position link plate spring anchors, ensure that link plate springs are in middle position

- a. Loosen link plate spring locknuts on inner side of link plate springs (Figure 12).
 - b. Turn adjuster bolts clockwise to increase tension and counterclockwise to release tension (Figure 13).
 - c. Adjust track tension to specified value and tighten locknuts.
4. Check track alignment as follows:

WARNING

Before rotating track, ensure that track is clear. Any tools or other objects on track could be thrown back causing serious injury.

- a. Start engine and rotate track *slowly*.
- b. Check that track is well-centered and distance between edge of track and link plate is the same on each side (**Figure 14**).
- c. If track is not aligned, loosen link plate spring locknut and turn adjuster (on side where track is closer to link plate) clockwise until track is realigned.
- d. Tighten locknut and recheck track tension. Readjust if necessary.

NOTE: Track tension and alignment are interrelated. Do not adjust one without checking the adjustment of the other.

5. Remove block from rear of snowmobile.

Slide Suspension

1. Raise rear of snowmobile; block securely.
2. Measure track tension as in **Table 2**.
3. If track tension is incorrect perform the following:
 - a. Loosen locknuts on adjuster bolts located inside of rear idler wheels (**Figure 15**).
 - b. Turn adjuster bolts clockwise to increase tension and counterclockwise to release tension.
 - c. Adjust track tension to specified value and tighten locknuts.
4. Check track alignment as follows:

WARNING

Before rotating track ensure that track is clear. Any tools or other objects on track could be thrown back causing serious injury.

NOTE: Track tension and alignment are interrelated. Do not adjust one without checking the adjustment of the other.

- a. Start engine and rotate track *slowly*.
- b. Check that track is well-centered and distance between edge of track and frame is the same on each side.

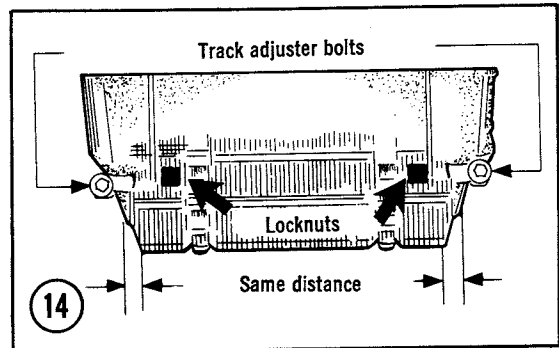
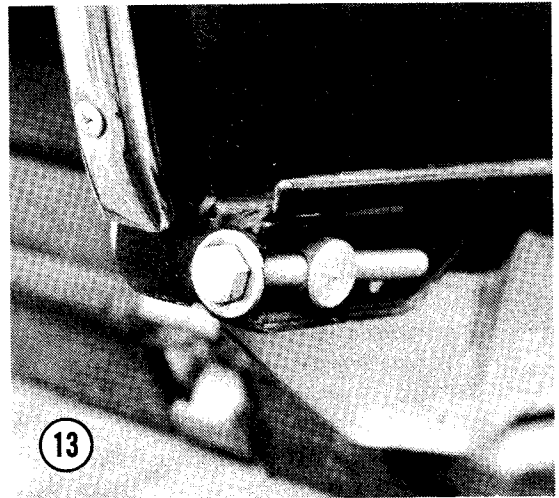

- c. If track is not aligned, loosen locknuts securing adjuster bolts and tighten adjuster on side where track is closer to frame.
- d. Tighten locknuts and recheck track tension. Readjust if necessary.
5. Remove block from rear of snowmobile.

**SLIDE SUSPENSION
RIDE ADJUSTMENT**

See **Table 3** for model application.

**Ground Leveler
and High Performance Suspension**

1. Raise rear of snowmobile and block up securely.
2. Tighten nuts on front spring adjuster bolts until outside of nut is $\frac{1}{8}$ - $\frac{3}{8}$ in. (15.9-22.2mm) from end of bolt (**Figure 16**). Ensure that both nuts are adjusted equally.

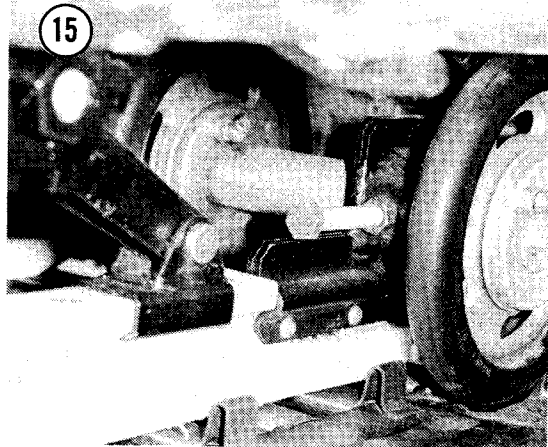

Table 3 SLIDE SUSPENSION MODEL

| Model | Suspension |
|---|------------------|
| Olympique 1970-1974 T'NT F/C 1970-1973 Elan 294 SS 1974 Elan 300 SS 1975 | Ground leveller |
| T'NT F/A 1973-1974 | High performance |
| All other models | Torque reaction |

3. Tighten nuts on rear spring adjuster bolts until outside of nut is $\frac{7}{8}$ - $1\frac{1}{8}$ in. (22.2-28.6mm) from end of bolt (Figure 16). Ensure that both nuts are adjusted equally.

4. Adjuster nuts can be tightened further if firmer ride is desired. Best all-around traction and ride are obtained if 5 in. (13 cm) clearance exists between rear of foot rest and the ground when driver is seated on snowmobile.

Torque Reaction Suspension

1. Measure distance between rear of foot rest and ground with driver in snowmobile. Distance should be $4\frac{1}{2}$ - $5\frac{1}{2}$ in. (11-14 cm).

NOTE: Front cam adjusters are for various snow conditions. Cams should be in lower position for deep snow and higher position for icy snow. Rear cams are adjusted for differing driver weights.

A spark plug wrench makes an ideal adjusting tool.

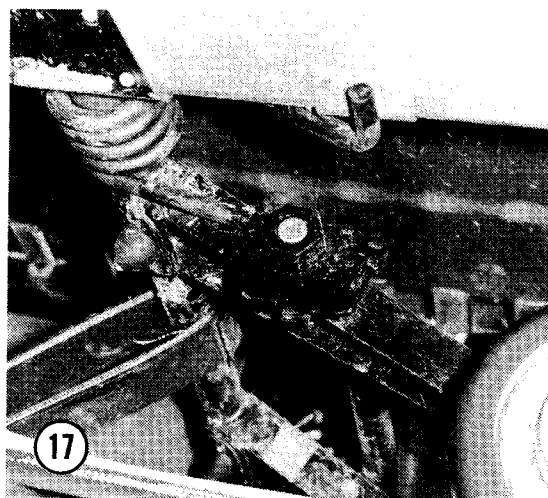
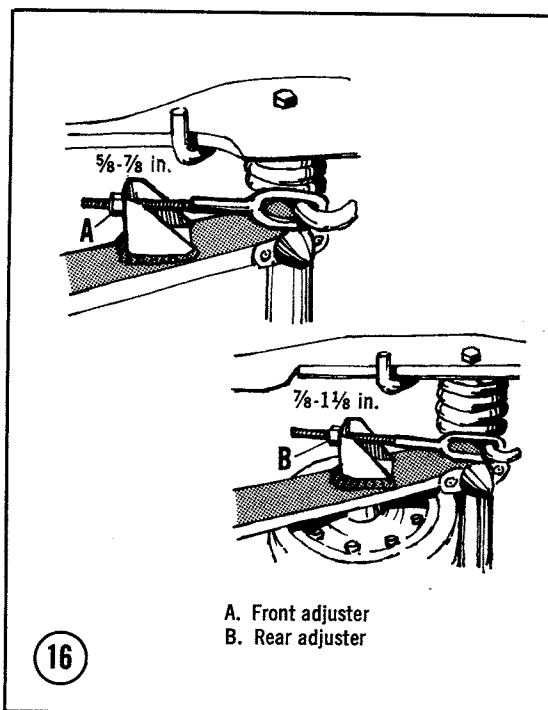

2. Adjust front cams as desired for snow conditions (Figure 17). Adjust rear cams for specified distance between foot rest and ground (Figure 18).

CAUTION

Always turn left side adjustment cams clockwise and right side cams counterclockwise. Ensure that left front cam is set at the same elevation as right front and left rear is set the same as right rear.

HARDWARE AND COMPONENT TIGHTNESS CHECK

Hardware and components on all machines should be checked at least once a year. An ideal time is when the machine is placed in or removed from storage. Check the tightness of all bolts, nuts, and fasteners. Check for any damaged or worn parts, and areas that require special attention or repair. Refer to **Figure 19** for forward engine models and **Figure 20** for mid-engine models.

ENGINE TUNE-UP

In order to maintain your snowmobile in proper running condition, the engine must receive periodic tune-ups. Since different systems in an engine interact to affect overall performance, the tune-up procedures should be performed in a sequence with time spent to double check all adjustments.

Normal tune-up procedures should begin with ignition adjustment, then be followed by carburetor adjustment. Since all adjustments interact, recheck items like idle adjustments after completing the entire tune-up procedure.

Always check the condition of spark plug wires, ignition wires, and fuel lines for splitting, loose connections, hardness, and other signs of deterioration. Check that all manifold nuts and carburetor nuts are tight and no crankcase leaks are present. A small air leak can make a good

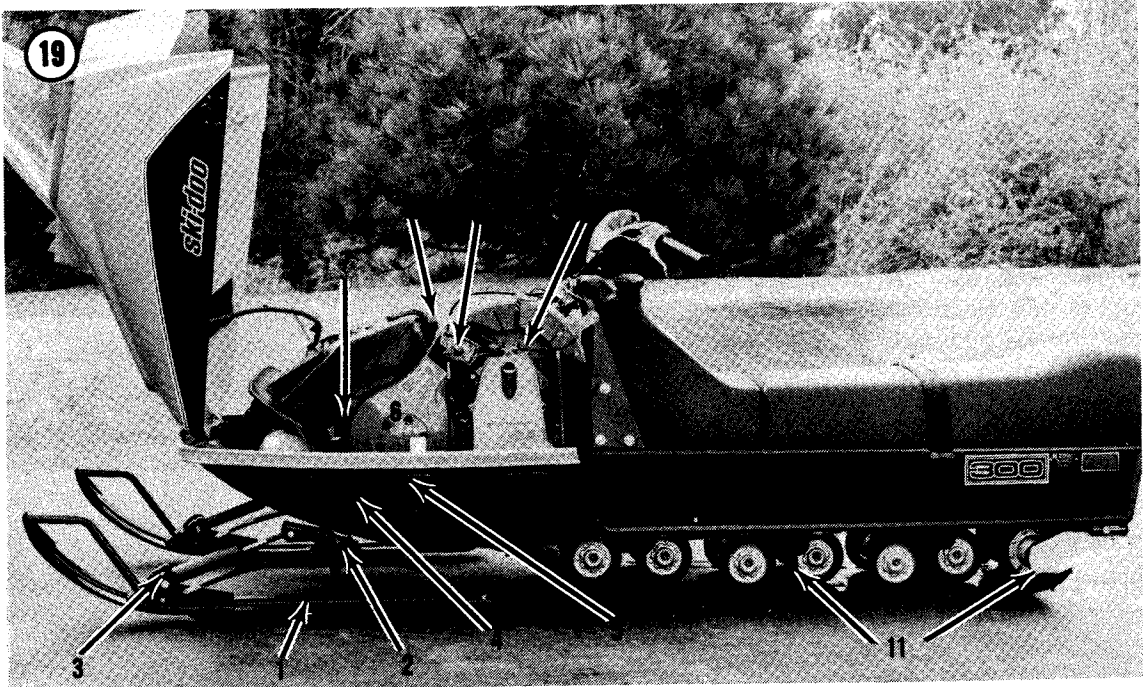
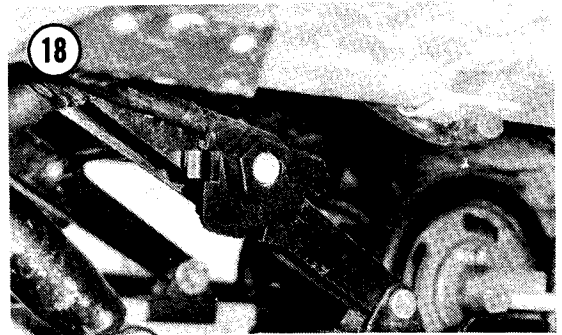

- | | |
|----------------------------------|--------------------------------------|
| 1. Ski runner nuts | 7. Engine mounting bolts |
| 2. Ski bolts | 8. Carburetor attaching nuts on band |
| 3. Shock absorber attaching bolt | 9. Air silencer and fuel lines |
| 4. Steering arm cap screws | 10. Driven pulley support |
| 5. Tie rod end locknuts | 11. Suspension components |
| 6. Drive pulley retaining bolt | |

tune-up impossible as well as affect performance. A small air leak can also cause serious damage by allowing the engine to run on a "too-lean" fuel mixture.

Tune-up Hints

The following list of general hints will help make a tune-up easier and more successful:

1. Always use good tools and tune-up equipment. The money saved from one or two home tune-ups will more than pay for good tools; from that point you're money ahead. Refer to Chapter One for suitable types of tune-up/test equipment.
2. The purchase of a small set of ignition wrenches and one or two "screwholding" or magnetic screwdrivers will ease the work in replacing breaker points and help eliminate losing small screws.
3. Always purchase quality ignition components.

4. When using a feeler gauge to set breaker points, ensure that the blade is wiped clean before inserting between the points.

5. Ensure that points are fully open when setting gap with a feeler gauge.

6. Be sure that feeler gauge is not tilted or twisted when it is inserted between the contacts. Closely observe the points and withdraw the feeler gauge slowly and carefully. A slight resistance should be felt, however, the movable contact point must *not* "spring back" even slightly when the feeler gauge blade is removed.

7. If breaker points are only slightly pitted, they can be "dressed down" lightly with a small ignition point file. *Do not* use sandpaper as it leaves a residue on the points.

8. After points have been installed, always ensure that they are properly aligned, or premature pitting and burning will result (**Figure 21**). Bend only the *fixed* half of the points; not the movable arm.

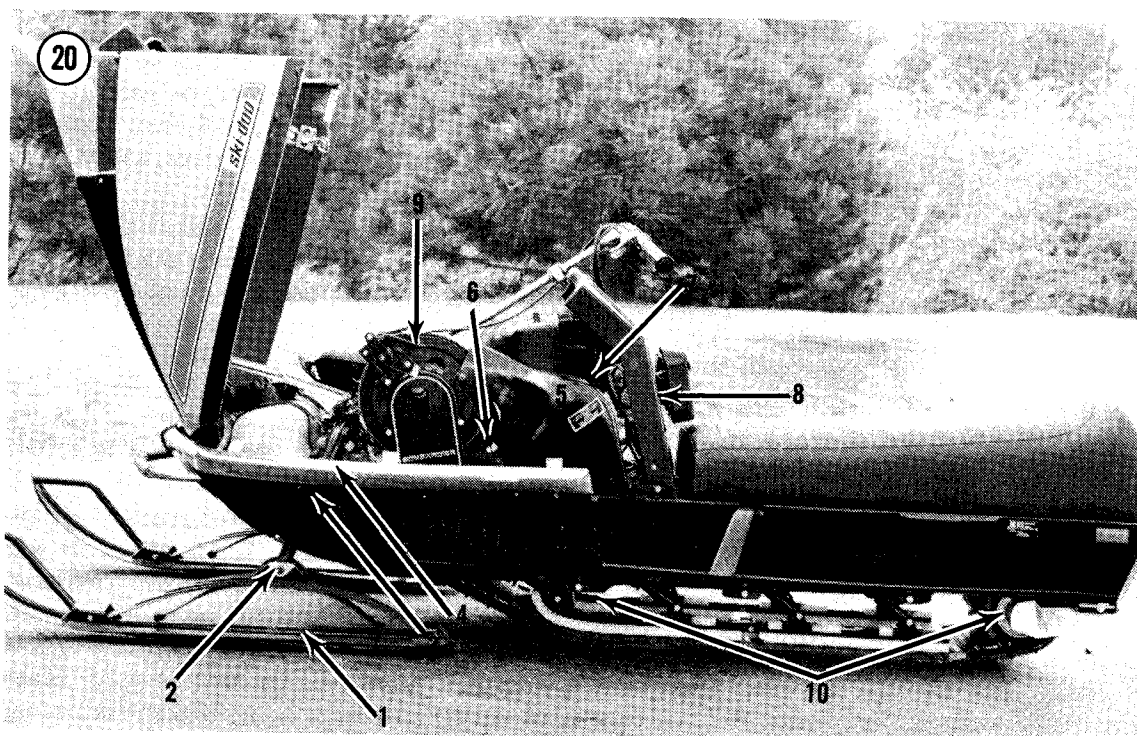

1. Ski runner nuts
2. Ski bolts
3. Steering arm cap screws
4. Tie rod end locknuts
5. Drive pulley retaining bolt

6. Engine mounting bolts
7. Carburetor attaching nuts
8. Air silencer and fuel lines
9. Driven pulley support on hinge rod
10. Suspension components

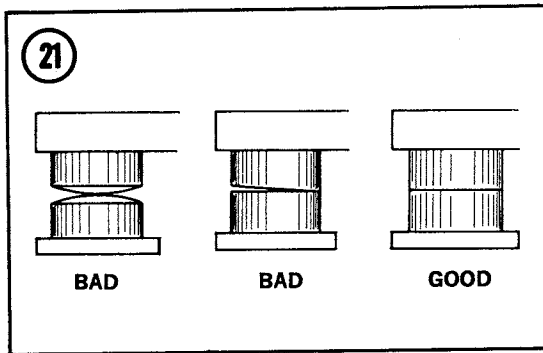

9. When point gap has been set, spring points open and insert a piece of clean paper or cardboard between the contacts. Wipe the contact a few times to remove any trace of oil or grease. A small amount of oil or grease on the contact surfaces will cause the points to prematurely burn or arc.

10. When connecting a timing light or timing tester, always follow the manufacturer's instructions.

Spark Plugs

Among the first steps to be done during any tune-up is to remove and examine the spark plug. Condition of a used spark plug can tell much about engine condition and carburetion to a trained observer.

To remove the spark plug, first clean the area around its base to prevent dirt or other foreign material from entering the cylinder. Next, unscrew the spark plug, using a $\frac{1}{8}$ in. deep socket. If difficulty is encountered removing a spark plug, apply penetrating oil to its base and allow some 20 minutes for the oil to work in. It may also be helpful to rap the cylinder head lightly with a rubber or plastic mallet; this procedure sets up vibrations which helps the penetrating oil to work in.

The proper heat range for spark plugs is determined by the requirement that the plugs operate hot enough to burn off unwanted deposits, but not so hot that they burn themselves or cause preignition. A spark plug of the correct heat range will show a light tan color on the portion of the insulator within the cylinder after the plug has been in service. **Figure 22** illustrates the different construction of the various heat ranges.

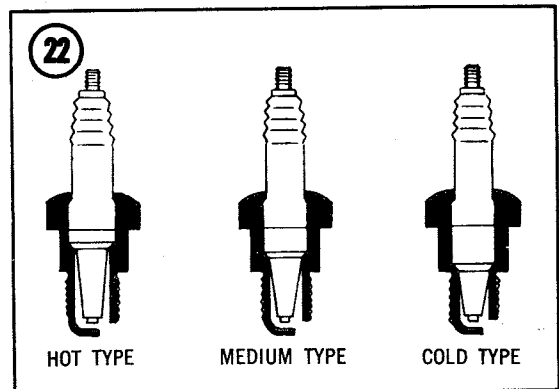

Table 4 CAUSES OF FOULED PLUGS

- | | |
|-----------------------------|--------------------------------|
| • Improper fuel/oil mixture | • Weak ignition |
| • Wrong type of oil | • Excessive idling |
| • Idle speed too low | • Wrong spark plugs (too cold) |
| • Clogged air silencer | |

Figure 23 illustrates various conditions which might be encountered upon plug removal.

1. *Normal condition* — If plugs have a light tan or gray colored deposit and no abnormal gap wear or erosion, good engine, carburetion, and ignition condition are indicated. The plug in use is of the proper heat range, and may be serviced and returned to use.

2. *Oil fouled* — This plug exhibits a black insulator tip, damp oily film over the firing end, and a carbon layer over the entire nose. Electrodes will not be worn. Common causes for this condition are listed in **Table 4**.

Oil fouled spark plugs may be cleaned in a pinch, but it is better to replace them. It is important to correct the cause of fouling before the engine is returned to service.

3. *Overheated* — Overheated spark plugs exhibit burned electrodes. The insulator tip will be light gray or even chalk white. The most common cause of this condition is using a spark plug of the wrong heat range (too hot). If it is known that the correct plug is used, other causes are lean fuel mixture, engine overloading or lugging, loose carburetor mounting, or timing advanced too far. Always correct the fault before putting the snowmobile back into service. Such plugs cannot be salvaged; replace with new ones.

SPARK PLUG CONDITIONS

23

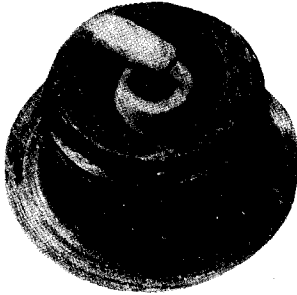

NORMAL USE

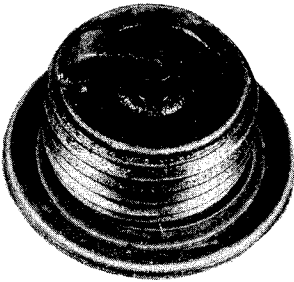

OIL FOULED

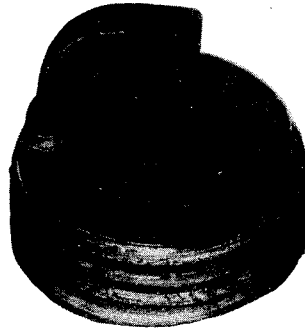

CARBON FOULED

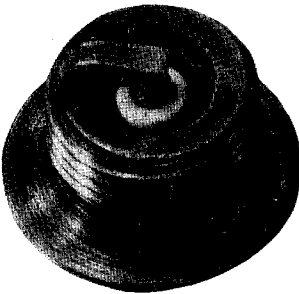

OVERHEATED

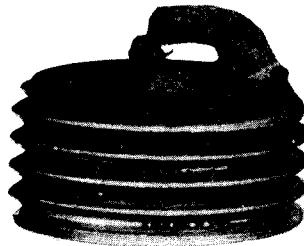

GAP BRIDGED

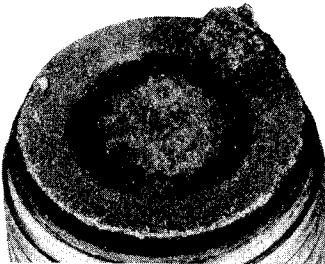

SUSTAINED PREIGNITION

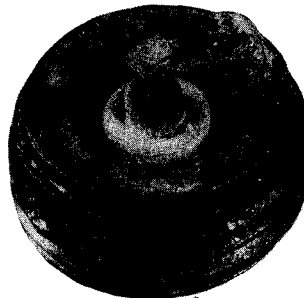

WORN OUT

Photos courtesy of Champion Spark Plug Company.

4. *Preignition* — If electrodes are melted, preignition is almost certainly the cause. Check for carburetor mounting or intake manifold leaks, also overadvanced ignition timing. It is also possible that a plug of the wrong heat range (too hot) is being used. Find the cause of preignition before placing the engine back into service.

5. *Carbon fouled* — Soft, dry sooty deposits are evidence of incomplete combustion and can usually be attributed to rich carburetion. This condition is also sometimes caused by weak ignition, retarded timing, or low compression. Such a plug may usually be cleaned and returned to service, but the condition which causes fouling should be corrected.

6. *Gap bridging* — Plugs with this condition exhibit gaps shorted out by combustion chamber deposits used between electrodes. On 2-stroke engines either of the following may be the cause:

- a. Improper fuel/oil mixture
- b. Clogged exhaust

Be sure to locate and correct the cause of this spark plug condition. Such plugs must be replaced with new ones.

7. *Worn out* — Corrosive gases formed by combustion and high voltage sparks have eroded the electrodes. Spark plugs in this condition require more voltage to fire under hard acceleration; often more than the ignition system can supply. Replace them with new spark plugs of the same heat range.

The spark plugs recommended by the factory are usually the most suitable for your machine. If riding conditions are mild, it may be advisable to go to spark plugs one step hotter than normal. Unusually severe riding conditions may require slightly colder plugs. See **Table 5**.

CAUTION

Ensure that spark plugs used have the correct thread reach. A thread reach too short will cause the exposed threads in the cylinder head to accumulate carbon, resulting in stripped cylinder head threads when the proper plug is installed. A thread reach too long will cause the exposed spark plug threads to accumulate carbon resulting in stripped cylinder head threads when the plug is removed.

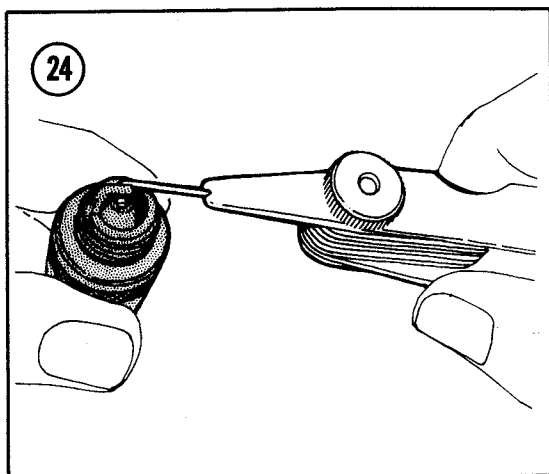

It may take some experimentation to arrive at the proper plug heat range for your type of riding. As a general rule, use as cold a spark plug as possible without fouling. This will give the best performance.

Remove and clean spark plugs at least once a season. After cleaning, inspect them for worn or eroded electrodes. Replace them if in doubt about their condition. If the plugs are serviceable, file the center electrodes square, then adjust the gaps by bending the outer electrodes only. Measure the gap with a round wire spark plug gauge only; a flat gauge will yield an incorrect reading. **Figure 24** illustrates proper spark plug gap measurement. Gap should be 0.020 in. (0.51mm).

Be sure to clean the seating area on the cylinder head and use a new gasket whenever you replace a spark plug. Install the plug fingertight, then tighten it an additional $\frac{1}{2}$ turn. If using a torque wrench, torque spark plugs to 20 ft.-lb. (2.8 mkg), for 14mm plugs and 30 ft.-lb. (4.1 mkg) for 18mm plugs.

Single Cylinder Engine Breaker Point and Timing Adjustment

Refer to list of general tune-up hints as outlined under *Engine Tune-Up*.

1. Remove spark plug.
2. Remove recoil starter and starting pulley from magneto ring (**Figure 25**).
3. Rotate crankshaft until breaker points are fully open (viewed through magneto ring). See **Figure 26**.

Table 5 SPARK PLUG APPLICATION

| Model | Champion | | Bosch | |
|--|----------|----------------|--|--------------|
| | Standard | Gold Palladium | Standard | Silver Sport |
| Elan 250; Olympique 300 (299 engine) | K-9 | K-8G | M175T1 | — |
| Olympique 335, 440 (1973) | K-9 | K-8G | M225T1 | — |
| Olympique 300 (1976) | | | | |
| T'NT F/A, T'NT R/V, T'NT 440 (1973) (14mm heads) and R/V 340 | RM-2 | N-2G | W280MZ2 | W280S1S |
| Elan 250 Twin and Deluxe to 1977 Olympique 300T, 340, 399, T'NT 399 | L-81 | L-6G | W240T1 | W260S1S |
| Olympique 300 Twin (1978 and later) Olympique 340, 340E (1978 and later) Citation 300 (1978 and later) Everest 340, 340E (1978 and later) | L-78 | L-4G | W280MZ1 | — |
| T'NT 340 (1978) | L-78 | L-4G | W260MZ1 | — |
| Blizzard 6500, 7500, 9500 | — | — | W340S2S | — |
| Blizzard 5500 | — | — | W275T2 | — |
| Everest 440, 440E; T'NT 440 L/C | K-7 | K-5G | M260T1 | W260S1S |
| Everest 444 L/C | N-3 | N-3G | W260MZ2 or W280MZ2 with 2 gaskets | |
| Elan 250SS, 300SS; T'NT 294, 300, 340 Everest 340 (to 1977); Olympique 340 (to 1977); T'NT 292 single; T'NT 440; Everest 440 (to 1977) | L-78 | L-4G | M260T1 | — |

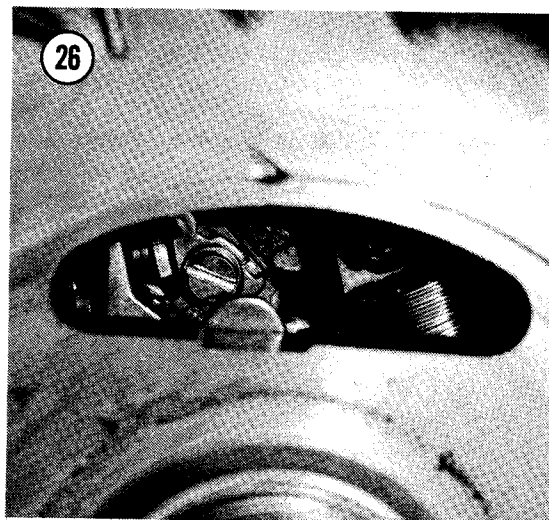
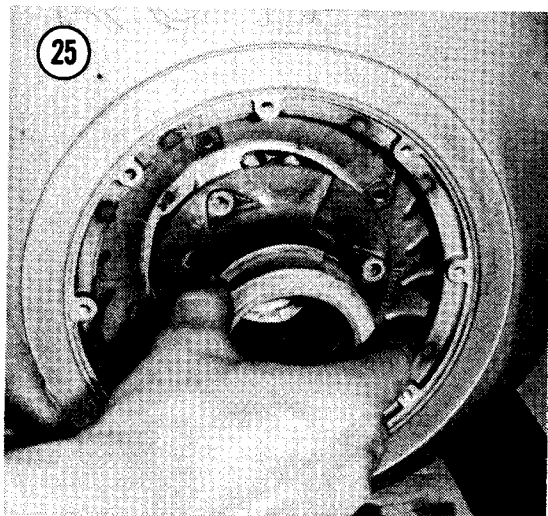

4. Carefully examine points and dress with file or replace as necessary.
5. Loosen screw securing breaker points. Using a feeler gauge set breaker point gap to 0.014-0.018 in. (0.35-0.45mm). Tighten screw securing breaker points. Recheck gap as gap can change when screw is tightened, readjust if necessary.
6. Disconnect electrical junction block at engine and connect a flashlight-type or tone-type timing tester. Connect one lead to black wire leading from engine and the other lead to a good ground such as fan cowl.

NOTE: More precise timing can be achieved by using a dial indicator-type gauge as described in Chapter One. If dial indicator gauge is used proceed to Step 9. If gauge is not used perform next step.

7. Turn on flashlight or tone tester and rotate magneto until timing marks align (**Figure 27**).
8. Loosen 3 screws retaining armature plate (**Figure 28**, magneto/fan assembly removed for clarity) and rotate plate until timing light fluctuates or tone signal changes. This indicates points are just starting to open. Tighten armature plate retaining screws. Recheck point gap and timing and readjust if necessary. Proceed to Step 14.

NOTE: In order to get breaker points to just begin to open when timing marks are aligned, it may be necessary to slightly change breaker point gap, however never vary gap beyond specified tolerance of 0.014-0.018 in. (0.35-0.45mm).

9. Install dial indicator gauge in spark plug hole. Rotate engine until piston is at TDC (top dead center) and "zero" gauge according to manufacturer's instructions (**Figure 29**).
10. Rotate engine until dial indicator gauge indicates piston is BDC (before top dead center) the amount specified in **Table 6**.

*NOTE: On engines with vertical spark plug hole use direct timing specification, **Table 6**. Engines with spark plug hole on an angle use indirect timing specifications.*

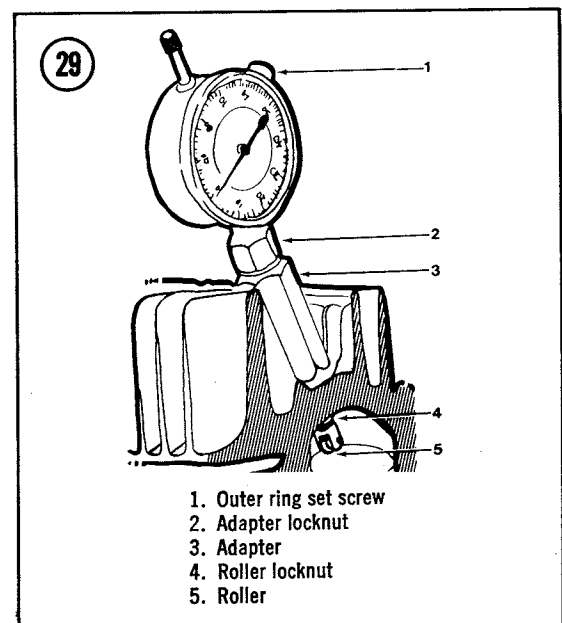
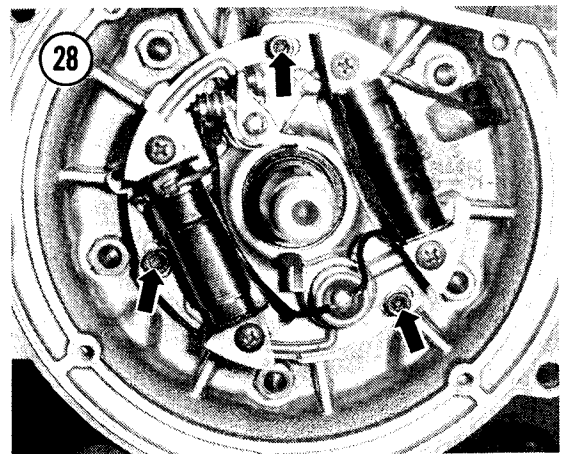
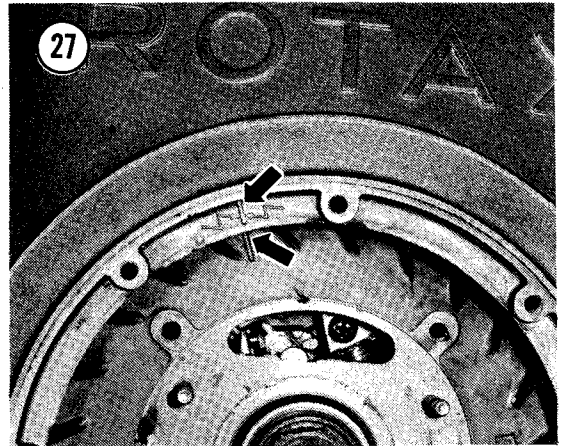

Table 6 IGNITION TIMING SPECIFICATIONS

| Engine | Direct Timing BTDC ¹ | Indirect Timing BTDC ¹ |
|------------------------------|---------------------------------|-----------------------------------|
| 245 (1976)* | 0.035-0.055 in. (0.90-1.40mm) | N/A |
| 245 (1975)* | 0.037-0.057 in. (0.95-1.45mm) | N/A |
| 247 | 0.147-0.167 in. (3.73-4.23mm) | N/A ² |
| 248, 249 | 0.077-0.097 in. (1.97-2.47mm) | 0.080-0.100 in. (2.04-2.54mm) |
| 250 | 0.150-0.170 in. (3.81-4.31mm) | 0.150-0.160 in. (3.81-4.06mm) |
| 292 (1970-1971) | 0.140-0.160 in. (3.55-4.06mm) | 0.195-0.221 in. (4.95-5.61mm) |
| 292, 302 (1972) | 0.147-0.167 in. (3.73-4.23mm) | 0.195-0.215 in. (4.95-5.46mm) |
| 294 | 0.084-0.104 in. (2.14-2.64mm) | 0.087-0.110 in. (2.19-2.79mm) |
| 300 | 0.150-0.170 in. (3.81-4.31mm) | 0.205-0.241 in. (5.20-6.12mm) |
| 302 | 0.147-0.167 in. (3.73-4.23mm) | 0.212-0.244 in. (5.38-6.20mm) |
| 305 | 0.111-0.131 in. (2.82-3.32mm) | 0.135-0.159 in. (3.43-4.03mm) |
| 304, 343 ³ (1978) | 0.073-0.093 in. (1.86-2.36mm) | 0.087-0.107 in. (2.21-2.71mm) |
| 335 | 0.160-0.180 in. (4.06-4.57mm) | 0.220-0.250 in. (5.59-6.35mm) |
| 337 | 0.157-0.177 in. (3.99-4.49mm) | 0.229-0.249 in. (5.81-6.32mm) |
| 338 | 0.111-0.131 in. (2.82-3.32mm) | 0.132-0.154 in. (3.35-3.89mm) |
| 340 (1970) | 0.160-0.180 in. (4.06-4.57mm) | 0.198-0.228 in. (5.02-5.79mm) |
| 340 (1971) | 0.160-0.180 in. (4.06-4.57mm) | 0.193-0.220 in. (4.90-5.59mm) |
| 343 (1972) | 0.137-0.157 in. (3.48-3.98mm) | 0.159-0.179 in. (4.03-4.55mm) |
| 343 (1973) | 0.111-0.131 in. (2.82-3.32mm) | 0.131-0.154 in. (3.33-3.91mm) |
| 343 | 0.111-0.131 in. (2.82-3.32mm) | 0.135-0.159 in. (3.43-4.03mm) |
| 345* | 0.035-0.055 in. (0.90-1.40mm) | N/A |
| 345 (1978)* | 0.034-0.054 in. (0.87-1.37mm) | N/A |
| 346 (1973)* | 0.109-0.129 in. (2.77-3.28mm) | N/A |
| 396 (1973)* | 0.060-0.080 in. (1.52-2.03mm) | N/A |
| 346, 396 (1974)* | 0.071-0.091 in. (1.82-2.32mm) | N/A |
| 354*, 454* | 0.045-0.065 in. (1.14-1.64mm) | N/A |
| 399, 440 (1970, 1971) | 0.160-0.180 in. (4.06-4.57mm) | 0.148-0.171 in. (3.76-4.34mm) |
| 401, 434, 435 (1972) | 0.137-0.157 in. (3.48-3.98mm) | 0.146-0.166 in. (3.71-4.22mm) |
| 401 | 0.111-0.131 in. (2.82-3.32mm) | 0.135-0.159 in. (3.43-4.03mm) |
| 434, 440 ⁴ | 0.111-0.131 in. (2.82-3.32mm) | 0.118-0.144 in. (2.99-3.66mm) |
| 435 | 0.111-0.131 in. (2.82-3.32mm) | 0.119-0.141 in. (3.02-3.58mm) |
| 436* | 0.071-0.091 in. (1.82-2.32mm) | N/A |
| 440 (1975)* | 0.71-0.091 in. (1.82-2.32mm) | 0.077-0.097 in. (1.96-2.46mm) |
| 440 (1978-1979) | 0.111-0.131 in. (2.82-3.32mm) | 0.120-0.140 in. (3.05-3.55mm) |
| 444 | 0.082-0.102 in. (2.10-2.60mm) | N/A |
| 503 | 0.068-0.088 in. (1.82-2.32mm) | N/A |

*Engines equipped with CDI.

1. Use direct timing for engines with vertical spark plug holes and indirect timing for engines with spark plug on an angle.
2. On 1972 models, indirect specification is the same as direct.
3. On 343 engines serial number 3,019,645 to 3,020,644 direct timing is 0.147-0.167 in. (3.73-4.23mm).
4. Except 1975 440 with CDI.

11. Turn on flashlight or tone tester and loosen 3 screws securing armature plate (Figure 28).
12. Hold advance mechanism weight in full advance position (toward magneto ring). See Figure 30.
13. Slowly rotate armature plate until timing light fluctuates or tone signal changes. This indicates points are just starting to open. Tighten armature plate retaining screws. Recheck point gap and timing, readjust if necessary.
14. Remove timing tester. Remove dial indicator gauge if used. Connect electrical junction block.
15. Install starting pulley and recoil starter. Install spark plug.

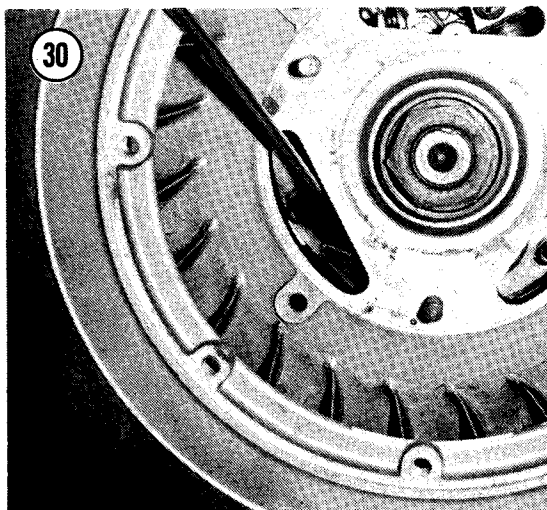

Twin Cylinder Engine Breaker Point and Timing Adjustment

Refer to list of general tune-up hints as outlined under *Engine Tune-Up*.

1. Remove spark plugs.
2. Remove recoil starter and fan cover.
3. Remove starting pulley and fan drive belt (Figure 31).
4. Rotate crankshaft until breaker points are fully open (viewed through magneto ring opening). See Figure 32.

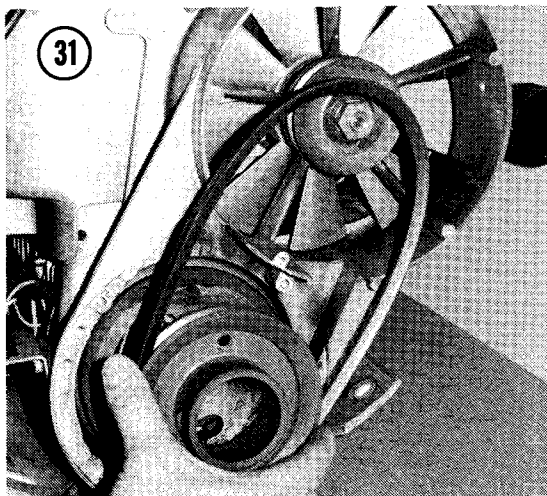

NOTE: Upper breaker points apply to magneto side piston; lower points apply to PTO (power take off) side.

5. Carefully examine points and dress with file or replace as necessary.
6. Loosen screw securing breaker points. Using a feeler gauge set breaker point gap to 0.014-0.018 in. (0.35-0.45mm). See Figure 32. Tighten screw securing breaker points. Recheck gap as gap can change when screw is tightened; readjust if necessary. Repeat for other set of breaker points.
7. Disconnect electrical junction block at engine and connect a flashlight-type or tone-type timing tester. Connect one lead to blue wire (magneto side points) leading from engine. Connect other lead to a good ground such as fan cowl.

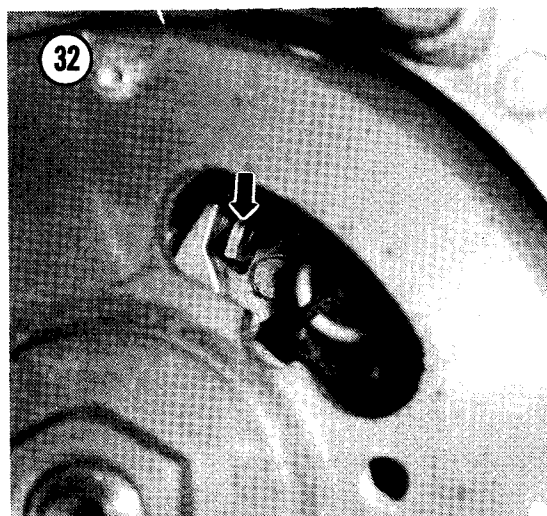

NOTE: More precise timing can be achieved by using a dial indicator-type

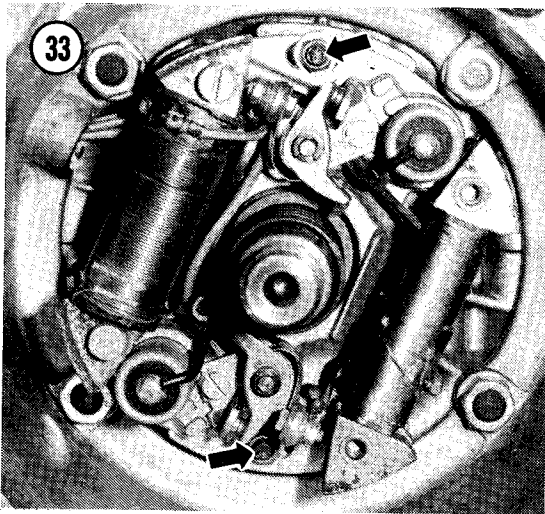

gauge as described in Chapter One. If dial indicator gauge is used proceed to Step 13. If gauge is not used perform next step.

8. Loosen 2 screws or nuts securing armature plate (Figure 33, magneto removed for clarity).

9. Turn on flashlight or tone tester and rotate crankshaft until magneto side piston approaches TDC (top dead center) and timing marks align (Figure 34).

10. Rotate armature plate until timing light fluctuates or tone signal changes. This indicates points are just starting to open. Tighten armature plate retaining screws. Rotate crankshaft counterclockwise approximately ¼ turn and then slowly rotate crankshaft back clockwise until timing marks are aligned. Check that points just start to open. Tightening armature plate retaining screws can cause timing to shift slightly. Readjust timing if necessary.

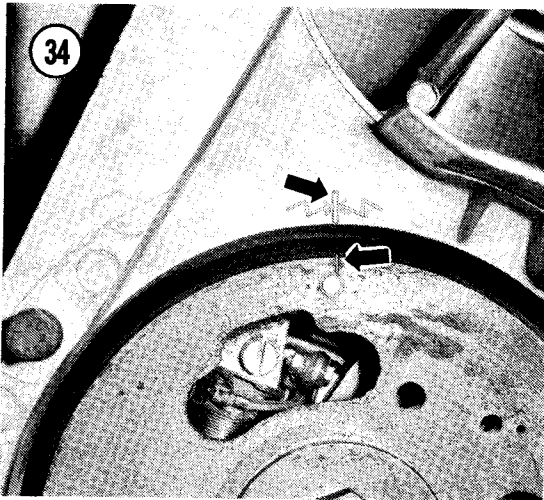

NOTE: It is necessary to hold centrifugal advance mechanism in the fully advanced position (toward magneto rim) while rotating armature plate to set timing (Figure 35) on the following engines:

305 engines

343 engines, serial No. 2,670,920 and subsequent

346 engines

402 engines

440 engines, serial No. 2,748,146 and subsequent

444 engines

11. Disconnect timing tester lead from blue wire and connect to blue/red (PTO side points) leading from engine.

12. Turn on timing tester and rotate crankshaft until timing marks align. Timing light should fluctuate or tone signal should change. If timing is incorrect adjust lower set of points as follows:

- a. If timing is too early, decrease point gap toward lower limit, 0.014 in. (0.35mm), until correct timing is achieved.
- b. If timing is too late, increase point gap toward upper limit, 0.018 in. (0.45mm), until correct timing is achieved.

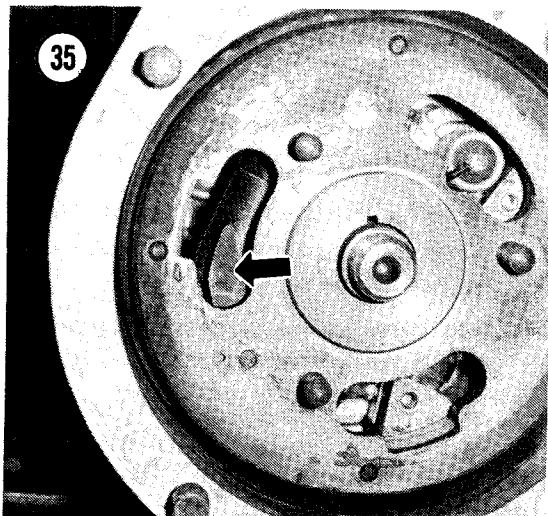

- c. After tightening breaker point retaining screw, recheck timing and readjust if necessary. Proceed to Step 19.
13. Install dial indicator gauge in magneto side spark plug hole. Rotate crankshaft until piston is at TDC (top dead center) and "zero" gauge according to manufacturer's instructions (**Figure 29**).
14. Loosen 2 screws or nuts securing armature plate (**Figure 33**, magneto removed for clarity). Turn on timing tester and rotate crankshaft until piston is specified distance BTDC (before top dead center), **Table 6**.

NOTE: *On engines with vertical spark plug hole use direct timing specifications, Table 6. Engines with spark plug hole on an angle use indirect timing specifications.*

15. Hold advance mechanism in fully advanced position (toward magneto ring) and slowly rotate armature plate until light fluctuates or tone signal changes (**Figure 35**). Tighten plate retaining screws and recheck timing. Readjust if necessary.
16. Disconnect timing tester lead from blue wire and connect to blue/red wire (PTO side points) leading from engine.
17. Remove dial indicator gauge from magneto side and install in PTO side spark plug hole and "zero" gauge when piston is at TDC.
18. Hold advance mechanism in fully advanced position and rotate crankshaft until piston is specified distance BTDC, **Table 6**. Timing light should fluctuate or tone signal should change. If timing is incorrect, adjust lower set of points as follows:

NOTE: *Do not loosen screws on armature ring or magneto side timing will be changed, requiring complete timing procedure to be repeated.*

- If timing is too early, decrease point gap toward lower limit, 0.014 in. (0.35mm), until correct timing is achieved.
- If timing is too late, increase point gap toward upper limit, 0.018 in. (0.45mm), until correct timing is achieved.

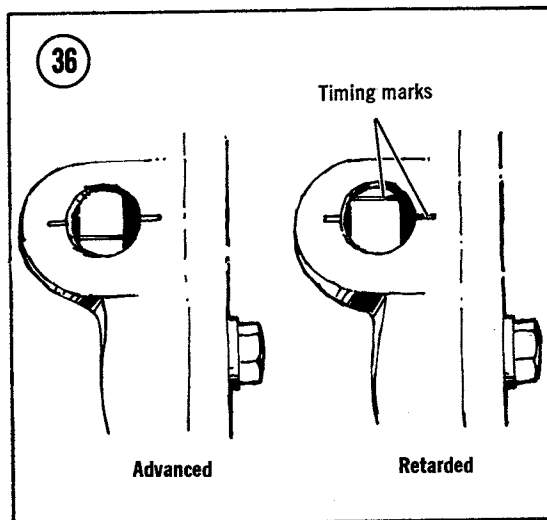

- c. After tightening breaker point retaining screw, recheck timing and readjust if necessary.
19. Remove timing tester. Remove dial indicator gauge if used. Connect electrical junction block.
20. Install starting pulley and fan belt.
21. Install recoil starter, fan cover, and spark plugs.

CDI Ignition Timing (Except 354 Engines)

- Raise rear of snowmobile off ground and block up securely.

WARNING

Ignition timing requires engine be run at 5,000 rpm. Ensure that track area is clear, pulley guard is in place, and no one walks behind track or serious injuries may result.

- Remove rubber plug from upper crankcase.
- Connect an external powered timing light to magneto side spark plug wire.

NOTE: *If DC powered timing light is used, connect light to an external battery.*

- Start engine and run up to 5,000 rpm. Timing marks on crankcase and magneto ring should align (**Figure 36**). If marks do not align perform the following:

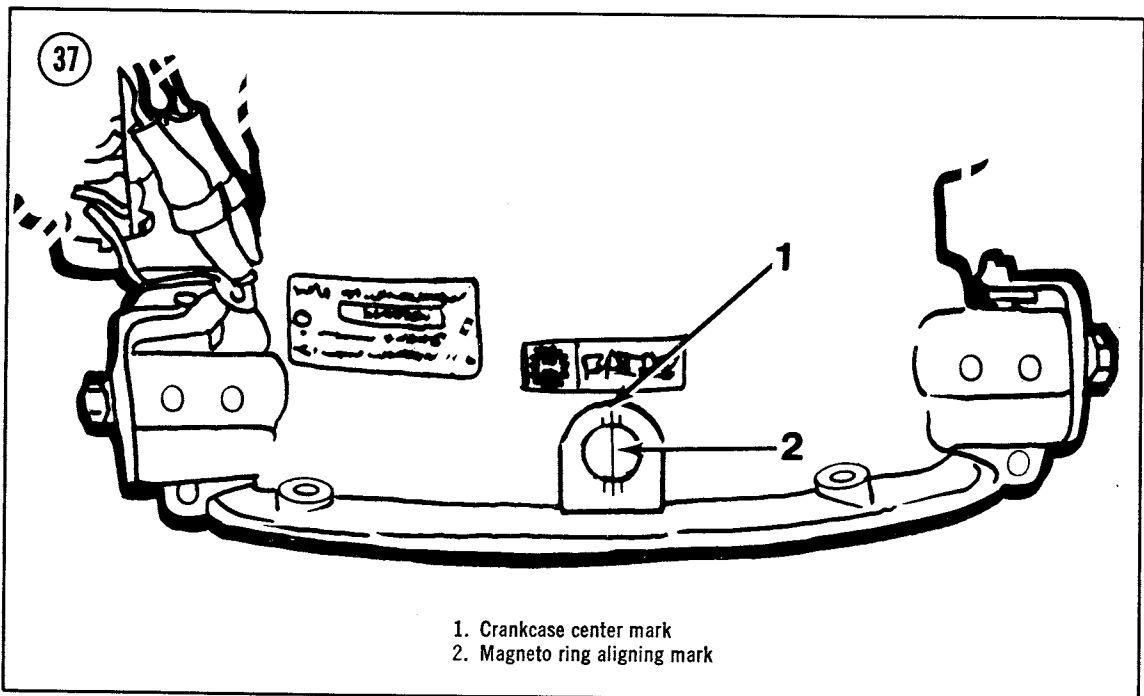

CAUTION

Do not run engine more than necessary or excessive slider shoe wear may result.

- a. Remove recoil starter and starting pulley.
 - b. Loosen Allen screws securing armature plate. Rotate plate clockwise to retard timing and counterclockwise to advance timing.
 - c. Recheck timing and readjust if necessary.
5. With engine off, connect timing light to PTO (power take off) side spark plug wire.
6. Start engine and run up to 5,000 rpm. Timing should coincide with magneto side timing. If PTO timing is incorrect perform the following:
- a. Remove PTO spark plug and install a dial indicator timing gauge (described in Chapter One) in spark plug hole.
 - b. Rotate engine until piston is at TDC (top dead center) and "zero" gauge according to manufacturer's instructions.
 - c. Rotate crankshaft until piston is specified distance BTDC (before top dead center). See **Table 6**.
 - d. Scribe marks on magneto rings for lower and upper limits of specified dimension. Repeat for magneto side piston.

- e. Position armature plate so both cylinders fire within upper and lower limits of specified timing tolerance.
7. Remove timing light and install rubber plug in crankcase.
 8. Install starting pulley and recoil starter if removed.
 9. Remove block from rear of snowmobile.

CDI Ignition Timing (354 Engines)

1. Raise rear of snowmobile off ground and block up securely.

WARNING

Ignition timing requires engine be run at 6,000 rpm. Ensure that track area is clear, pulley guard is in place, and no one walks behind track or serious injuries may result.

2. Remove rubber plug from upper crankcase.
3. Install dial indicator gauge in spark plug hole. Rotate crankshaft until piston is at TDC (top dead center) and "zero" gauge according to manufacturer's instructions (**Figure 29**).
4. With piston at TDC, rotate crankshaft until piston is positioned 0.055 in. (1.40mm) BTDC.

Check that timing mark on the magneto ring aligns with the center mark on the crankcase as shown in **Figure 37**. If timing marks are incorrect, remark magneto ring. Repeat for the other piston.

5. Check air gap between the magneto ring and each trigger coil as shown in **Figure 38**. If air gap is incorrect, magneto ring will have to be removed and the armature plate repositioned (refer to *Flywheel and Magneto Removal* in Chapter Four). Air gap for each trigger coil should be 0.040-0.063 in. (1-1.6mm).

6. Connect an external powered timing light to magneto side spark plug wire. Use an external battery if using a DC powered timing light.

7. Start engine and run up to 6,000 rpm. Timing mark on magneto ring should align as shown in **Figure 37**. If marks do not align, perform the following:

- a. Loosen screw securing trigger coil bracket and adjust bracket up or down slightly until timing is correct (**Figure 39**). Repeat for the other cylinder.

NOTE: Magneto trigger coil is on carburetor side and PTO trigger coil is on exhaust side.

- b. If insufficient travel of trigger coil bracket prevents correct timing, remove bracket and slightly move trigger coil on the bracket (**Figure 40**).

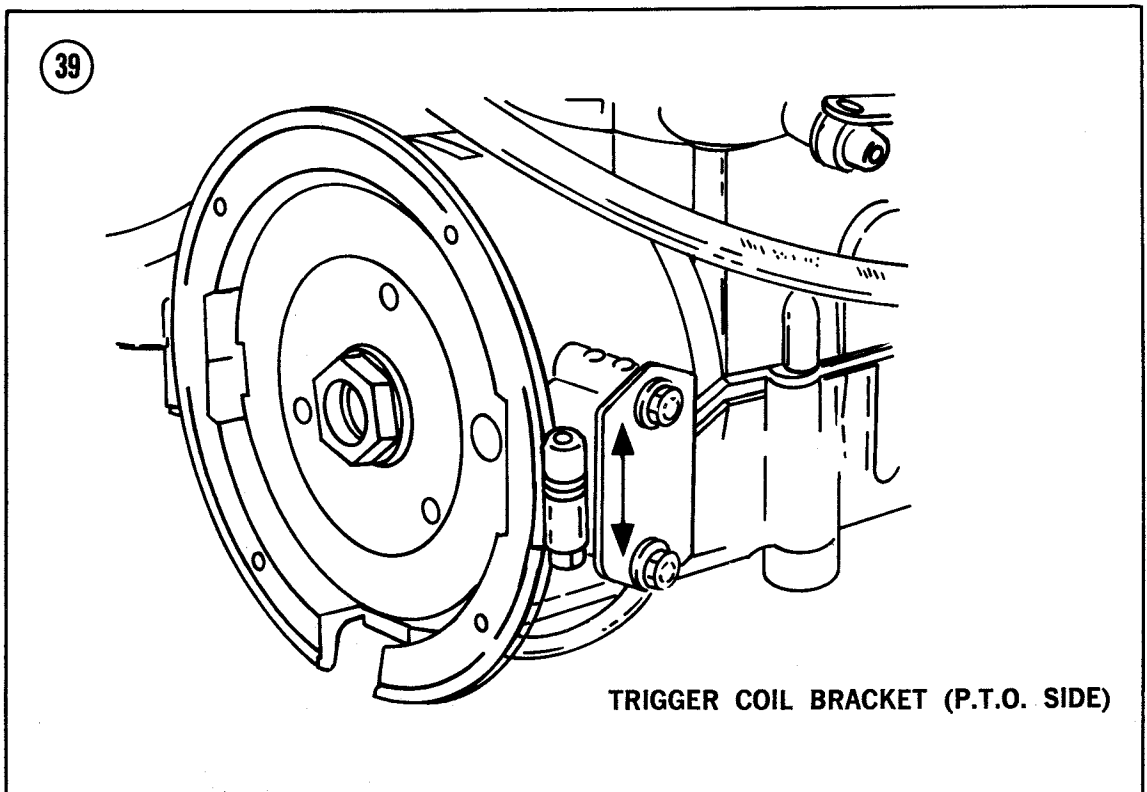
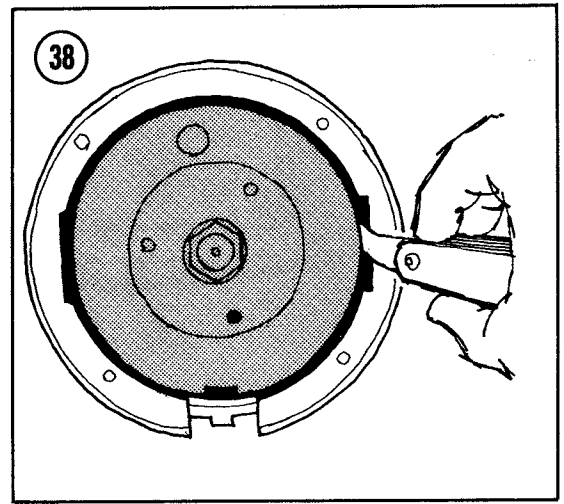

8. Remove timing light and install rubber plug in crankcase.
9. Remove block from rear of snowmobile.

**Throttle Cable Adjustment
(Tillotson Carburetors)**

Adjust throttle cable (A, **Figure 41**) so throttle lever on carburetor is fully open when throttle control on the handlebar is in the wide-open throttle position.

CAUTION

Do not adjust cable too tightly (throttle on carburetor is wide-open before throttle control is fully against handlebar) or cable may break due to excessive strain.

Tillotson Carburetor Adjustment

1. Gently close low-speed mixture needle (B, **Figure 41**) and high-speed mixture needle (A, **Figure 42**), if adjustable, until needle contacts seat. Back off mixture needles as specified in **Table 7**.

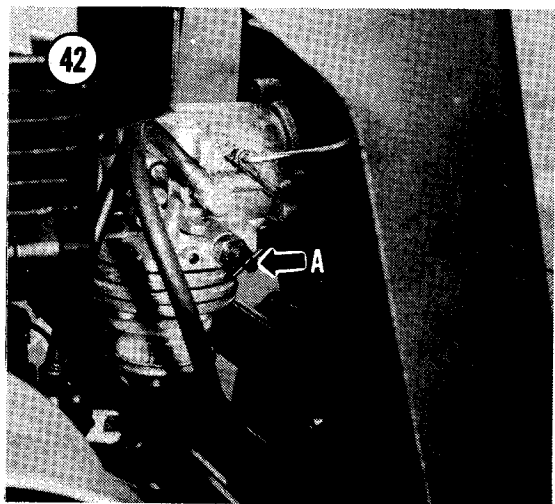
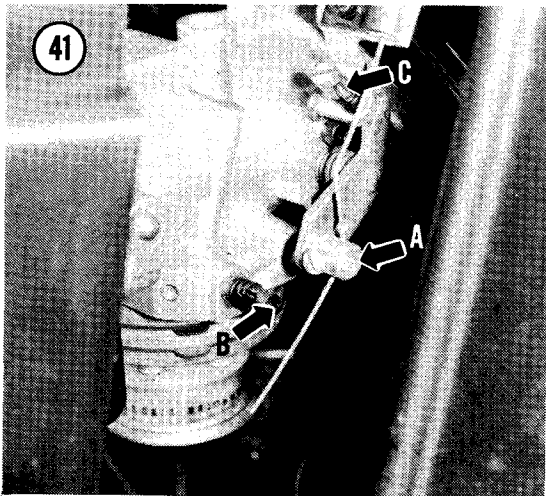
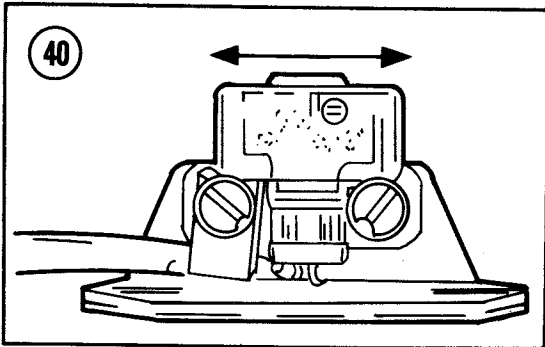

CAUTION

Close mixture needles carefully or damage to needle and/or seat may result.

2. Start and warm up engine. Turn idle speed adjustment screw (C, **Figure 41**) to achieve specified idle speed, **Table 7**.
3. Ensure that the high-speed needle (if adjustable) is set at specified preliminary setting, **Table 7**. Check and adjust mixture as follows:

CAUTION

If snowmobile is equipped with an air silencer, adjustments must be made with silencer installed or a "too lean" mixture and subsequent engine damage may result.

- a. Drive snowmobile approximately 1 mile at 6,000 rpm. Shut off engine with ignition switch or kill button; do not allow engine to idle.
- b. Remove spark plug(s) and examine insulator. A brownish tip indicates correct mixture. Black insulator indicates a "too rich" mixture and light grey insulator indicates a "too lean" mixture.
- c. If mixture is incorrect, adjust high-speed mixture needle. Turn needle clockwise to obtain a leaner mixture or counterclockwise to obtain a richer mixture. Adjust needle 1/8 turn at a time and repeat high-speed run and spark plug examination after each run.

Table 7 TILLOTSON CARBURETOR SPECIFICATIONS

| Model | Carburetor | Low Speed Adjustment (Turns)** | High Speed Adjustment (Turns)** | Idle Speed (rpm) |
|-------------------------------------|-------------|--------------------------------|---------------------------------|------------------|
| Elan | | | | |
| 250, 250 E (1971,1972, early 1973) | HR-73A | 3/4 | 1 1/4 ① | * |
| 250 (late 1973-1975) | HR-133A | 3/4 | Fixed | * |
| 292 SS (1972) | HD-22B | 3/4 | 1 1/4 | * |
| 250 T (1973) | HR-136A | 3/4 | Fixed | * |
| 250 T, 250 Deluxe (1974) | HR-155A | 1 | Fixed | * |
| 250 Deluxe (1975) | HR-165A | 1 | Fixed | * |
| 250 (1976) | HR-173A | 1 | Fixed | * |
| 250 SS (1973) | HR-143A (2) | 3/4 | Fixed | * |
| 294 SS (1974) | HR-161A | 3/4 | Fixed | * |
| 300 SS (1975) | HR-166A | 3/4 | Fixed | * |
| 250 SS (1976) | HR-172A | 1 | Fixed | 1,500-1,800 |
| 250 (1978-1979) | HR-173A | 1 | Fixed | 1,800-2,000 |
| 250 Deluxe (1978-1979) | HR-172A | 1 | Fixed | 1,800-2,200 |
| Olympique | | | | |
| 300 (1971-early 1973) | HR-74A | 3/4 | 1 1/4 | * |
| 300 (late 1973-1974) | HR-132A | 3/4 | 1 | * |
| 300 (1975 and 1976 twin) | HR-169A | 1 | Fixed | 1,500-1,800 |
| 300 (1976 single) | HR-174A | 1 | Fixed | 1,200-1,500 |
| 335 (1970) | HR-176 | 3/4 | 1 1/4 | * |
| 335 (1971-1973) | HR-75A | 3/4 ② | 1 1/4 ② | * |
| 340 (1973-1974) | HR-131A | 3/4 | Fixed | * |
| 340 (1975-1976) | HR-170A, B | 1 | Fixed | 1,500-1,800 |
| 399 (1970) | HR-16B | 3/4 | 1 1/4 | * |
| 399 (1971-1972) | HR-76A | 3/4 | 1 1/4 | * |
| 400 (early 1973) | HR-76A | 1 | 1 1/16 | * |
| 400 (late 1973-1974) | HR-134A | 3/4 | Fixed | * |
| 440 (1973-1974) | HR-135A | 7/8 | Fixed | * |
| 440 plus (1976) | HR-176A | 1 | Fixed | 1,500-1,800 |
| T'NT | | | | |
| 292, 340 (1970, 1971, and 1972 292) | HD-22A, B | 3/4 | 1 1/4 | * |
| 340 (1972) | HD-98A | 1 1/8 | 1 | * |
| 294 (1973) | HR-137A (2) | 3/4 | Fixed | * |
| 340 (1973) | HD-107A | 7/8 | Fixed | * |
| 300 (1974) | HR-164A | 1 | 1 | * |
| 340 (1974-1975) | HD-134A | 1 | 1 | * |
| 340 (1976) | HD-148A | 1 | 1 | 1,500-1,800 |
| 399 (1970) | HD-21A | 3/4 | 1 1/4 | * |
| 440 (1971) | HD-73A | 3/4 | 1 1/4 | * |

(continued)

Table 7 TILLOTSON CARBURETOR SPECIFICATIONS (continued)

| Model | Carburetor | Low Speed Adjustment (Turns)** | High Speed Adjustment (Turns)** | Idle Speed (rpm) |
|-----------------------------|-------------|--------------------------------|---------------------------------|------------------|
| TNT (con't.) | | | | |
| 440 (1972) | HD-83A | 1 1/4 | 1 1/4 | * |
| 440 (1973) | HD-109A | 1 | 1 | * |
| 440 and Everest (1974-1975) | HD-138A | 1 | 1 | * |
| 440 and Everest (1976) | HD-147A | 1 | 1 | 1,500-1,800 |
| 400 F/A (1972) | HD-104A (2) | 3/4 | 1 1/4 | * |
| 340 F/A (1973-1974) | HR-149A (2) | 1 | 1 1/8 | * |
| 400 F/A (1973-1974) | HD-123A (2) | 1 | 5/8 | * |
| 340 F/A (1975) | HR-168A (2) | 1 | 1 1/8 | * |
| 440 F/A (1974) | HRM-3A (2) | 1 | 1 1/4 | * |
| 440 F/A (1975) | HRM-5A (2) | 1 | 1 | * |

* Unless otherwise specified, idle speed is 1,800-2,200 rpm.

** Tolerance for all adjustments is +1/8-0 turn.

① Fixed jet on later 1973 models.

② On 1973 models turn low-speed needle 7/8 and high-speed needle 1 1/16.

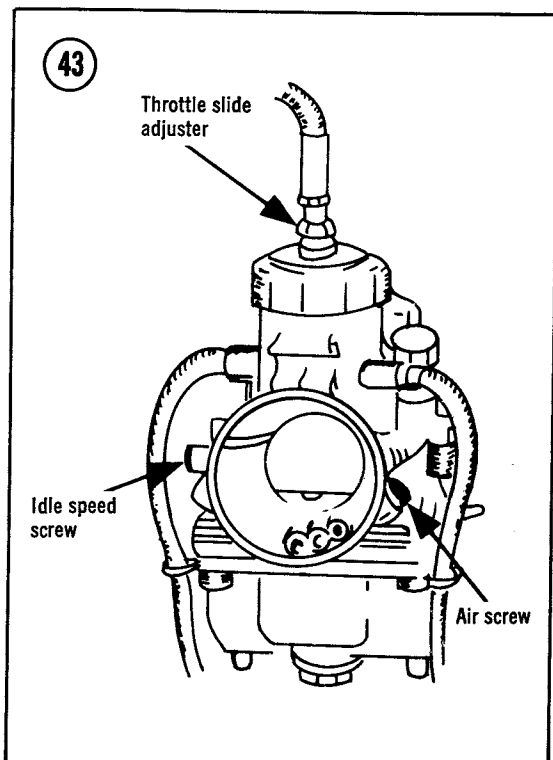

CAUTION

Continued operation with a "too lean" mixture can cause engine overheating and serious engine damage.

- d. If final adjustment is a considerable change from preliminary mixture needle setting, check for engine and/or carburetor air leaks, defective crankcase seals, or incorrect spark plug heat range.

Mikuni Carburetor Adjustment and Synchronization

This procedure includes throttle cable adjustments and idle speed adjustments for all models equipped with Mikuni carburetors.

On models equipped with 2 carburetors, more precise synchronization can be achieved with an air flow meter as described in Chapter One. If such a device is available, perform the following procedure as a preliminary adjustment and proceed to *Mikuni Carburetor Air Flow Meter Synchronization* for the final fine tuning.

Refer to **Figure 43** for this procedure.

Table 8 MIKUNI CARBURETOR SPECIFICATIONS

| Model | Carburetor | E-ring Position (From Top) | Air Screw Turns ($\pm \frac{1}{4}$ Turn) |
|----------------------------------|------------|-------------------------------|--|
| T'NT R/V 245 (1975) | VM 34-72 | 2 | 1 |
| T'NT 340-340E kit (1976) | VM 34-109 | 3 | 1 |
| T'NT 440-440E kit (1976) | VM 34-105 | 2 | 1 |
| Olympique 340-340E kit (1976) | VM 34-104 | 3 | 1 |
| Olympique 300-300E kit (1976) | VM 34-103 | 3 | 1 |
| T'NT R/V 250 (1976) | VM 34-93 | 2 | 1 |
| T'NT R/V 340 (1976) | VM 34-94 | 2 | 1 |
| Olympique 440 plus kit (1976) | VM 32-117 | 3 | 1½ |
| Olympique 300 (twin—1977-1978) | VM 30-90 | 3 | 1½ |
| Olympique 340-340E (1977-1979) | VM 30-91 | 3 | 1½ |
| Everest 340-340E kit (1977-1979) | VM30-98 | 3 | 1½ |
| Olympique 440 (1977) | VM 32-113 | 4 | 1½ |
| T'NT 340 F/A (1977-1978) | VM 34-118 | 3 | 1 |
| T'NT 440 F/A (1977) | VM 36-53 | 2 | 1 |
| T'NT 440 (1977) | VM 34-110 | 3 | 1½ |
| R/V 340 (1977-1978) | VM 34-135 | 4 | 1 |
| Everest 440-440E (1977) | VM 34-110 | 3 | 1½ |
| Everest 440 L/C (1977) | VM 34-150 | 4 | 1 |
| Citation 300 (1978) | VM30-94 | 3 | 1½ |
| Citation 300 (1979) | VM 30-104 | 3 | 1½ |
| Everest 440, 440E (1978) | VM 34-165 | 3 | 2 |
| T'NT 440 F/C (1978) | VM 34-165 | 3 | 2 |
| Everest 444 L/C | VM 34-150 | 4 | 1½ |
| Blizzard 6500 | VM 34-184 | 4 | 1½ |
| Blizzard 9500 | VM 36-78 | 4 | 1 |
| Blizzard 5500 | VM 34-203 | 3 | 1½ |
| Blizzard 7500 and Cross Country | VM 34-199 | 2 | 1½ |

1. Remove air intake silencer.
2. Use a strong rubber band and clamp throttle lever to handlebar grip in the wide-open-throttle position.
3. Loosen locknut securing throttle slide adjuster. Feel inside carburetor bore and turn adjuster until cut-out portion of throttle valve is flush with inside of carburetor bore (**Figure 44**).
4. Turn adjuster sleeve counterclockwise the required number of additional turns to position the backside of the throttle valve flush with the carburetor bore.
5. Rotate idle speed screw counterclockwise until the tip is flush with inside of carburetor bore.
6. Remove rubber band clamp from handlebar and allow throttle to return to idle position.
7. Turn in idle speed screw until tip just contacts throttle slide valve. Turn in stop screw 2 additional turns for a preliminary idle setting.
8. Slowly operate throttle lever on handlebar

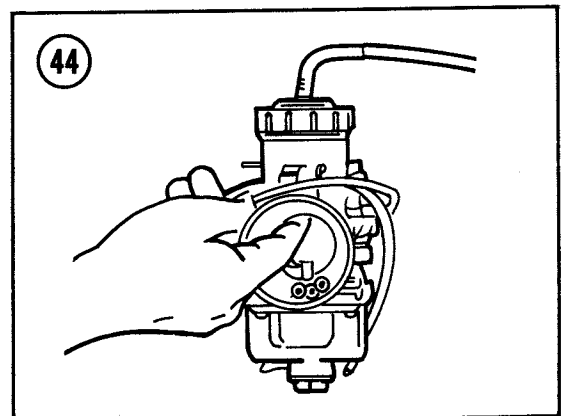

- and observe that throttle valve begins to rise. On models with 2 carburetors, ensure that throttle valves move an equal amount together. Readjust throttle cables if necessary.
9. Slowly turn in pilot air screw until light seating is felt. *Do not* force or air screw may be damaged. Back out pilot air screw number of turns specified in **Table 8**.

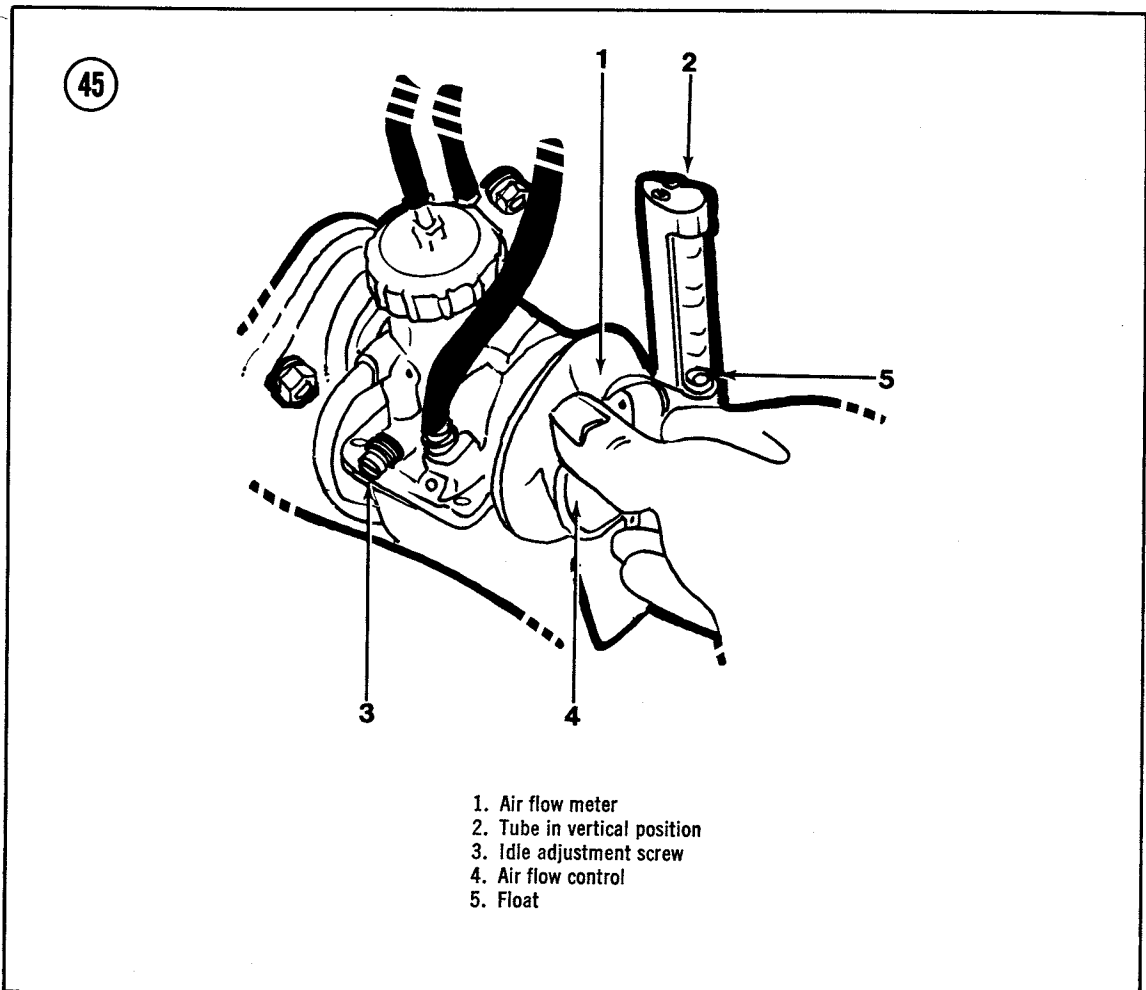

10. Install air intake silencer and start engine. Warm up engine to operating temperature and check idle speed. Adjust throttle stop screw as necessary for specified idle speed. On 2 carburetor models, ensure that both throttle stop screws are adjusted an equal amount.

CAUTION

Do not use pilot air screws to attempt to set engine idle speed. Pilot air screws must be set as specified in Table 8, or a "too lean" mixture and subsequent engine damage may result.

Mikuni Carburetor Air Flow Meter Synchronization

To obtain a precise synchronization of twin carburetor models, use an air flow meter device as described in Chapter One. Perform *Mikuni*

Carburetor Adjustment and Synchronization to obtain proper preliminary adjustments.

Refer to **Figure 45** for this procedure.

WARNING

The following procedure is performed with the engine running. Ensure that arms and clothing are clear of drive belt or serious injury may result.

1. Raise and support rear of snowmobile so track is clear of the ground.
2. Start engine. Wedge in throttle lever to maintain engine speed at 4,000 rpm.
3. Open air flow control of air flow meter and place meter over right carburetor throat. Tube on meter must be vertical.
4. Slowly close air flow control until float in tubes aligns with a graduated mark on tube.

5. Without changing adjustment of air flow control, place air flow meter on left carburetor. If carburetors are equal, no adjustment is necessary.
6. If adjustment is necessary, loosen cable adjuster locknut on carburetor with lowest float level and turn adjuster until air flow matches other carburetor. Tighten locknut.
7. Return engine to idle and repeat Steps 3, 4, and 5. Adjust throttle stop screws as necessary for a balanced idle.

Mikuni Carburetor Main Jet Selection

The main jet controls the fuel metering when the carburetor is operating in the ½ to full throttle range. Since temperature and altitude affect the air density, each snowmobile owner will have to perform the following trial and error method of jet selection to obtain peak engine efficiency and performance for his own particular area of operation.

CAUTION

Air intake silencer must be installed during the following procedure or a "too lean" mixture may result. A "too lean" fuel mixture can cause engine overheating and subsequent serious damage.

NOTE: Snowmobile must be operated on a flat, well-packed area for best results.

1. Operate machine at wide-open throttle for several minutes. If peak rpm cannot be achieved or engine appears to be laboring, main jet needs to be changed.
2. Make another trial run and shut off ignition while throttle is still wide open. Examine the exhaust and spark plugs to determine if mixture is too rich or too lean. Mixture is too rich if exhaust manifold or spark plug insulator is dark brown or black. Refer to *Spark Plugs* in this chapter. Decrease jet size if mixture is too rich.

NOTE: Change jet sizes one increment at a time and test after each change to obtain best results.

If manifold or spark plug insulator is a very light color, mixture is too lean. Correct by increasing jet size.

3. If state of fuel/air mixture cannot be determined by color of exhaust manifold or spark plug insulator, assume mixture is too lean and increase jet size. If operation improves, continue increasing jet size until maximum performance is achieved. If operation gets worse, decrease jet size until best results are obtained.

OFF-SEASON STORAGE

Proper storage techniques are essential to help maintain your snowmobile's life and usefulness. The off-season is also an excellent time to perform any maintenance and repair tasks that are necessary.

Placing in Storage

1. Use soap and water to thoroughly clean the exterior of your snowmobile. Use a hose to remove rocks, dirt, and debris from the track area. Clean all dirt and debris from the hood and console areas.

CAUTION

Do not spray water around the carburetor or engine. Be sure you allow sufficient time for all components to dry.

2. Use a good automotive type cleaner wax and polish the hood, pan, and tunnel. Use a suitable type of upholstery cleaner on the seat. Touch up any scratched or bare metal parts with paint. Paint or oil the skis to prevent rust.
3. Drain the fuel tank. Start the engine and run it at idle to burn off all fuel left in the carburetor. Check the fuel filter and replace if contaminated.
4. Wrap up carburetor(s) and intake manifold in plastic and tie securely.
5. Remove spark plugs and add a teaspoon of snowmobile oil to each cylinder. Pull the engine over several times with the starter rope to spread the oil over the cylinder walls. Replace the spark plugs.
6. Remove the drive belt. Apply a film of light grease to drive and driven pulleys to prevent rust and corrosion.
7. Change chaincase oil.

8. Raise rear of snowmobile off the ground. Loosen the track adjusting screws to remove any tension on the track.
9. Carefully examine all components and assemblies. Make a note of immediate and future maintenance and repair items and order the necessary parts. Perform *Hardware and Component Tightness Check*.
10. Cover snowmobile and store inside if possible.

Removing From Storage

1. Perform *Hardware and Component Tightness Check*.
2. Remove grease from the drive and driven

pulleys and install the drive belt.

3. Fill the fuel tank with new gasoline/oil mixture. Refer to Chapter One.
4. Check throttle and brake controls for proper operation and adjust if necessary.
5. Adjust the track to proper tension.
6. Familiarize yourself with all safety and operating instructions.
7. Start the engine and check the operation of the emergency stop switch. Check that all lights and switches operate properly. Replace any burned out bulbs.
8. Start out slowly on short rides until you are sure your machine is operating properly and is dependable.

