

CHAPTER SIX

ELECTRICAL SYSTEM

The electrical system on Ski-Doo snowmobiles consists of an ignition system, lighting system, and an optional electric starting system.

Two types of ignition systems are used: a breaker point magneto and capacitive discharge ignition (CDI). Refer to **Figures 1 and 2** for a typical example of each system.

The lighting system consists of a headlight, brake/taillight, and instrument lights.

The electric starting system is an optional package consisting of a battery, a starter with solenoid, and charging components.

This chapter includes testing and repair of some components of the ignition, lighting, and charging systems. Many of the testing and repair tasks referenced in this chapter require special testing equipment and tools. These tasks are best accomplished by an authorized dealer or competent auto electric shop.

Refer to Chapter Two for magneto breaker point and timing adjustments.

CDI SYSTEM

The capacitor discharge ignition system supplies high voltage to spark plugs without the use of breaker points as in a conventional magneto ignition system.

The CDI system electronic components are not repairable and must be replaced if found defective.

If ignition system malfunctions are experienced, perform the following troubleshooting procedure. Refer any additional testing and repairs to an authorized dealer.

CDI Troubleshooting

1. Check spark plugs (Chapter Two) and spark plug wires and replace if defective.
2. Disconnect junction block connected to engine kill button.
3. Start engine. If engine does not miss, replace kill button. If engine continues to miss or will not start, continue procedure.
4. On models equipped with trigger box, perform the following:
 - a. Disconnect violet and black/violet wires from timing box.
 - b. Connect ohmmeter between wires. Ohmmeter should indicate 55-60 ohms. If resistance is not as specified, magneto side cylinder pick-up coil is defective. Replace armature plate.
 - c. Disconnect black/yellow and violet/yellow wires from timing box.
 - d. Connect ohmmeter between wires. Ohmmeter should indicate 55-60 ohms. If resistance is not as specified, PTO side cylinder pick-up coil is defective. Replace armature plate.

1

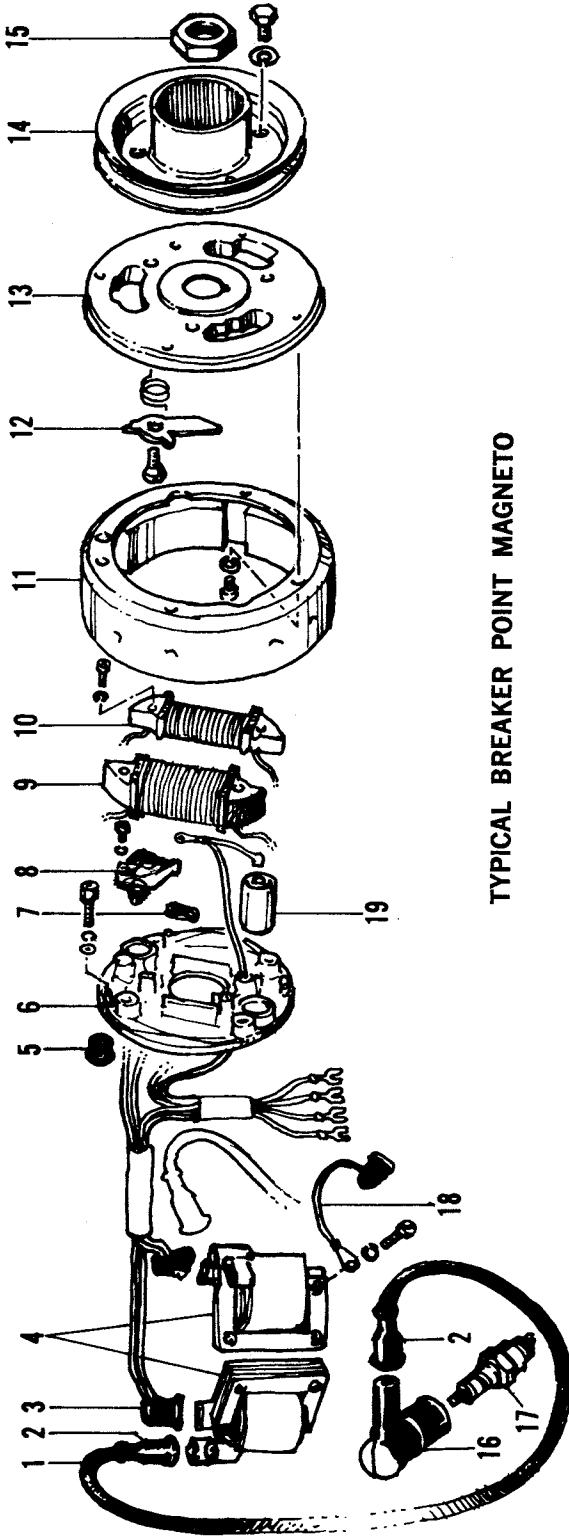

TYPICAL BREAKER POINT MAGNETO

- | | |
|----------------------|--------------------------|
| 1. H.T. cable | 11. Magneto ring |
| 2. Protector | 12. Centrifugal lever |
| 3. Boot | 13. Magneto housing |
| 4. H.T. coils | 14. Starting pulley |
| 5. Wire grommet | 15. Magneto nut |
| 6. Armature plate | 16. Spark plug protector |
| 7. Lubricating wick | 17. Spark plug |
| 8. Breaker point set | 18. Ground wire |
| 9. Lighting coil | 19. Capacitor |
| 10. Generator coil | |

2

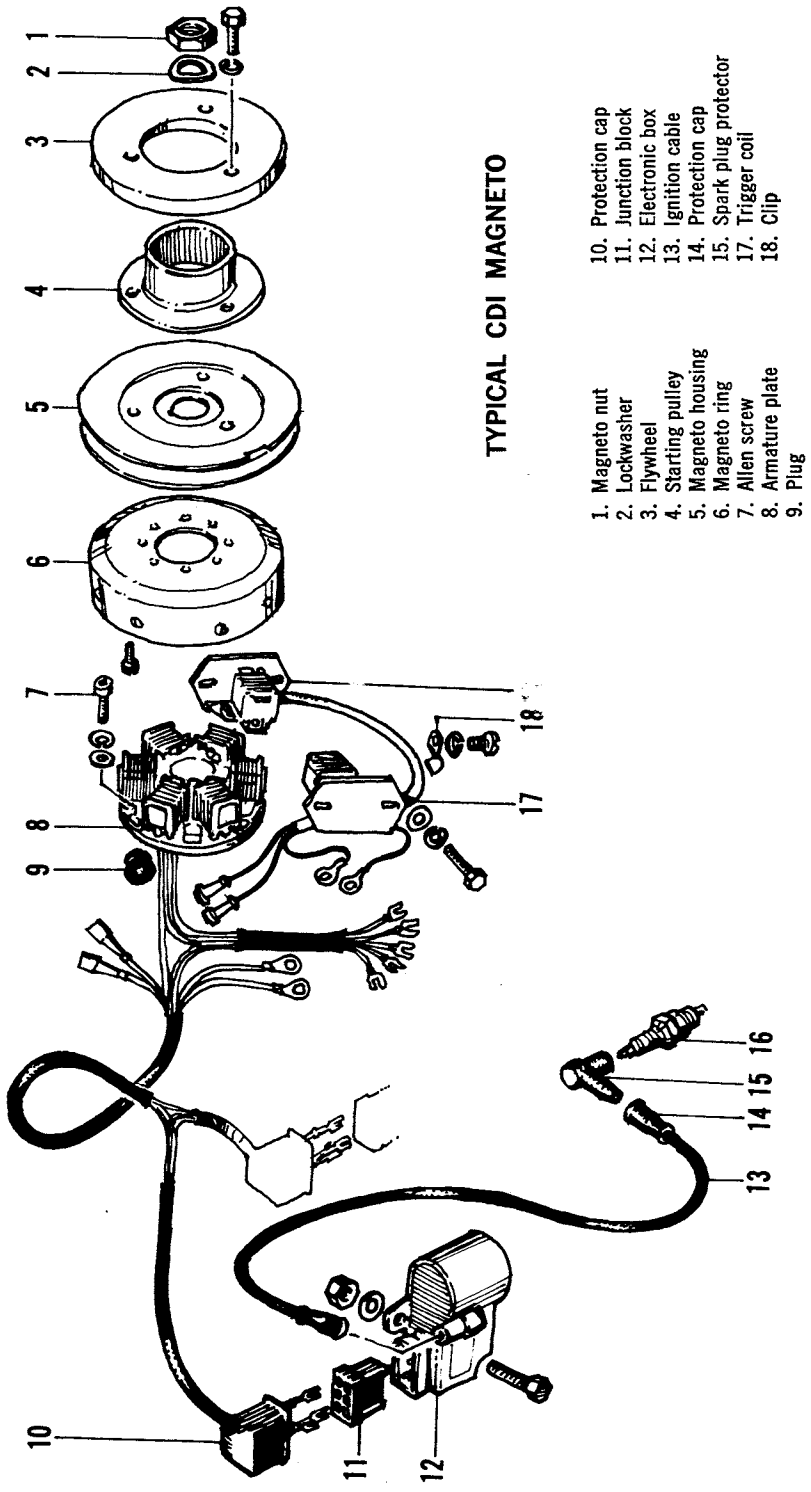

TYPICAL CDI MAGNETO

- 1. Magneto nut
- 2. Lockwasher
- 3. Flywheel
- 4. Starting pulley
- 5. Magneto housing
- 6. Magneto ring
- 7. Allen screw
- 8. Armature plate
- 9. Plug
- 10. Protection cap
- 11. Junction block
- 12. Electronic box
- 13. Ignition cable
- 14. Protection cap
- 15. Spark plug protector
- 16. Trigger coil
- 17. Trigger coil
- 18. Clip

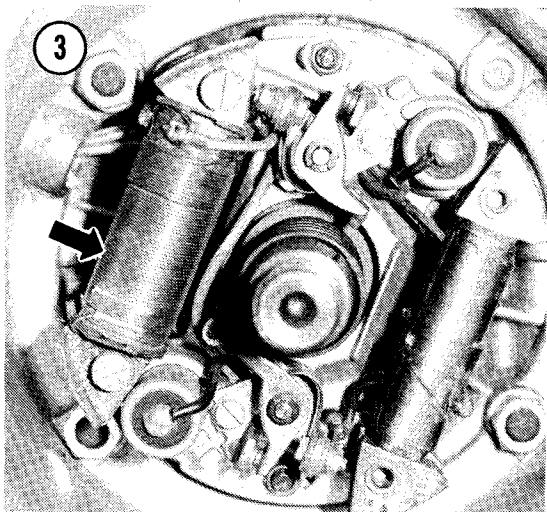

- e. If either pick-up coil is defective, remove armature plate assembly from engine as described in Chapter Four.
 - f. If both pick-up coils check out good, proceed to Step 6.
5. On models without trigger box, perform the following:
- a. Disconnect junction block from electronic box.
 - b. Connect ohmmeter between violet/yellow wire in junction block (not electronic box) and ground. Ohmmeter should indicate 55-60 ohms. If resistance is not as specified, PTO side cylinder pick-up coil is defective. Replace armature plate.
 - c. Connect ohmmeter between violet wire in junction block and ground. Ohmmeter should indicate 55-60 ohms. If resistance is not as specified, magneto side cylinder pick-up coil is defective. Replace armature plate.
 - d. If pick-up coils check out as specified and engine misfires on one cylinder, replace electronic box. If either pick-up coil is defective, remove armature plate assembly as outlined in Chapter Four.
 - e. If engine will not fire on either side, perform the next step.
6. If pick-up coils check out as specified, perform the following:
- a. Disconnect junction block from electronic box if not already disconnected.

- b. Connect ohmmeter between ground and red wire in junction block (not on electronic box). Ohmmeter should indicate 325-365 ohms.
- c. If resistance is not as specified, remove armature plate as outlined in Chapter Four and have an authorized dealer replace ignition generator coil.
- d. If resistance is within tolerance, replace electronic box.
- e. Reconnect all junction blocks.

MAGNETO IGNITION

The testing of ignition generating coil, condenser, brake light coil, and ignition coils requires expensive sensitive test equipment. If a malfunction is suspected in any of these components, have it tested by an authorized dealer or competent auto electric shop. They have the equipment and expertise for the task.

If malfunctions exist in ignition generating coil or condenser, remove armature plate as outlined in Chapter Four.

Refer to Chapter Two for breaker point and timing adjustments.

LIGHTING SYSTEM

The lighting system consists of a headlight and brake/taillight unit, instrument lights and an AC (alternating current) generating device. Switches control all lighting circuits. The lighting coil on the magneto armature plate generates AC current.

On models equipped with an electric starter, AC is converted (rectified) to DC (direct current) by a rectifier and then used to keep the battery charged.

Lighting Coil

Testing of lighting coil (Figure 3) requires expensive sensitive test equipment. If a lighting coil malfunction is suspected, remove magneto armature plate as outlined in Chapter Four and refer testing or repair to an authorized dealer.



Light Switch Test

1. Remove wire connectors from light switch.
2. Use an ohmmeter or flashlight continuity tester and test operation of switch in OFF and ON positions.
3. Replace switch if defective. Connect wires to switch.

Headlight Replacement

Lift retaining clips securing bulb socket (Figure 4). Twist and pull out bulb. Ensure that new bulb is of the same wattage rating as the old one.

Brake/Taillight Bulb Replacement

1. Remove screws (Figure 5) securing light lens and remove lens. On models without lens retaining screws, unsnap lens.
2. Push in and rotate bulb counterclockwise to remove (Figure 6).
3. Install new bulb making sure alignment pins on bulb are properly aligned.
4. Install lens and secure with retaining screws.

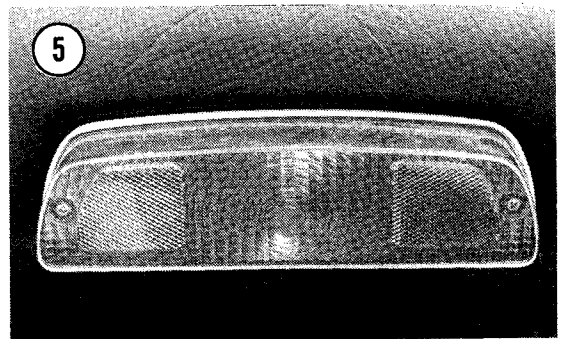

Headlight Adjustment

1. Position snowmobile on a flat surface with headlight 25 ft. (7.6m) from a vertical surface (Figure 7).
2. Turn on high beam. Light adjustment is correct if beam center is equal with horizontal beam line. Maximum horizontal deviation from center is 2 in. (5 cm). Maximum vertical deviation is 1 in. (2.5 cm).
3. If light alignment is incorrect, remove headlight ring and adjust upper and lower screws until beam is within specified tolerance.

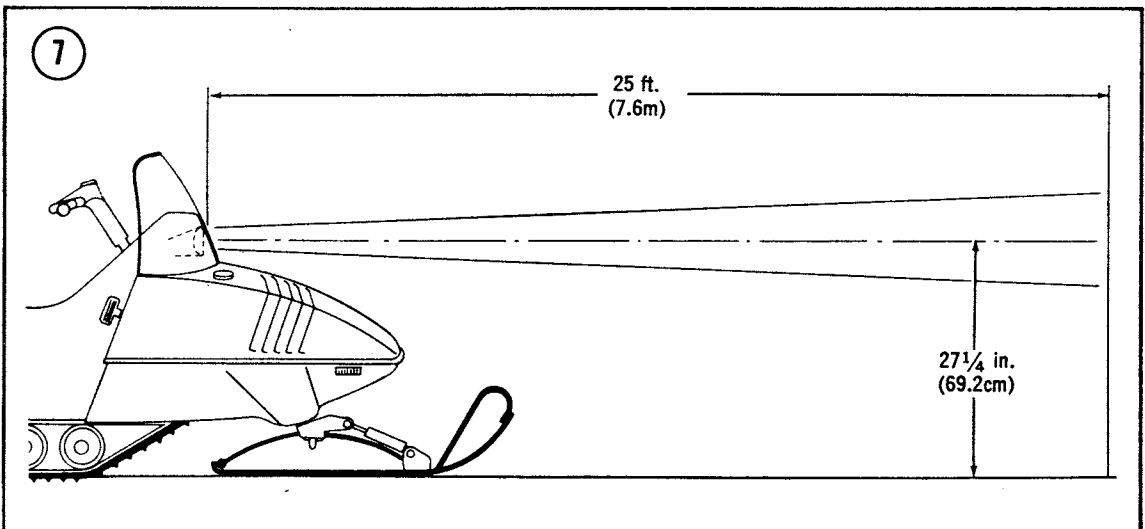
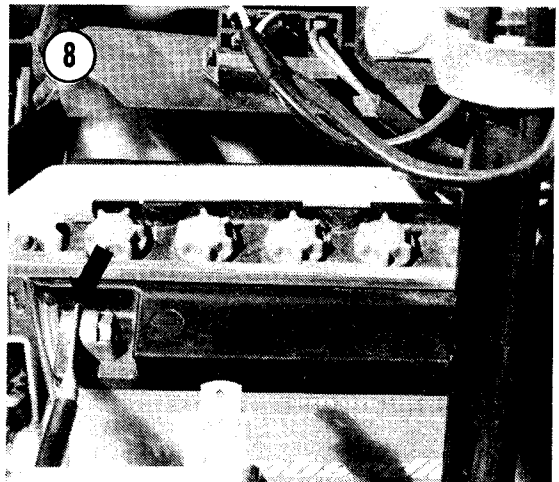
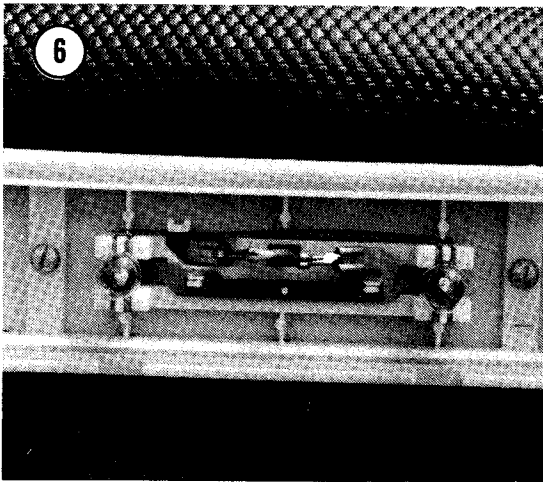

NOTE: On older models it may be necessary to use small wedges behind headlight ring to obtain desired deflection.

ELECTRIC STARTING SYSTEM

The electric starting system consists of a 12-volt battery, starter motor with solenoid and a rectifier.

The starter solenoid acts as a relay to route battery current to the starter as well as mechanically engage the starter drive. The starter drive engages with a ring gear on the engine to turn the engine over.

The battery is kept charged by current supplied by the lighting coil which is rectified to DC (direct current) by the rectifier.

Starter and Solenoid Removal/Installation

Starter testing and repair requires special tools. It is recommended that all starter service and repair be referred to an authorized dealer or competent auto electric shop.

1. Disconnect battery ground cable (**Figure 8**).
2. Disconnect battery cable and switch wires from solenoid (**Figure 9**).
3. Remove capscrews and washers securing starter bracket to crankcase (**Figure 10**).
4. Remove nuts and washers securing starter bracket to starter.

5. Remove nuts and washers securing starter to engine. Remove starter and solenoid with starter bracket.
6. Installation is the reverse of these steps.

Battery Removal/Installation

1. Disconnect negative (–) cable (**Figure 8**). Remove rubber boot and disconnect positive (+) cable.
2. Loosen hold-down bolts (**Figure 11**) and unhook bolts from battery box. Remove hold-down clamp.
3. Disconnect vent tube from battery. Carefully lift battery out of battery box.
4. Installation is the reverse of these steps. Keep the following points in mind:

CAUTION

Be sure battery connections are correct or serious damage to electrical components will occur.

- a. Be sure exterior of battery and terminals are clean and free from corrosion.
- b. Connect positive (+) cable to battery first.

Battery Cleaning and Service

Electrolyte level in the battery should be checked periodically, especially during periods of regular operation. Use only distilled water and top off battery to bottom of ring (filler neck) so the tops of the plates are covered. *Do not* overfill.

Battery corrosion is a normal reaction; however, it should be cleaned off periodically to keep battery deterioration to a minimum.

Remove battery and wire brush terminals and cable ends. Wash terminals and exterior of battery with about a 4:1 solution of warm water and baking soda.

CAUTION

Do not allow any baking soda solution to enter battery cells or serious battery damage may result.

Wash battery box and hold-down bolts with baking soda solution. Rinse all parts in clear water and wipe dry.

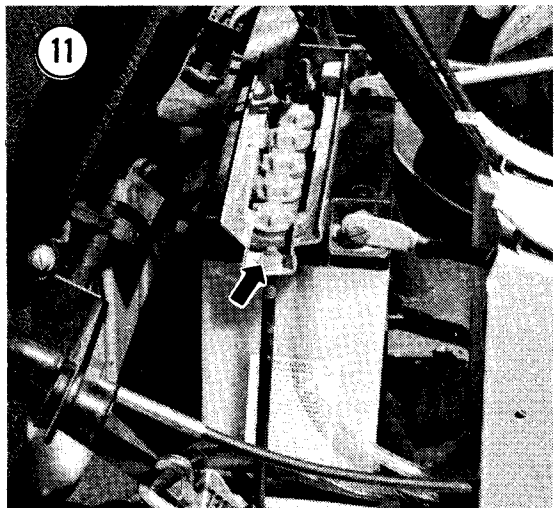
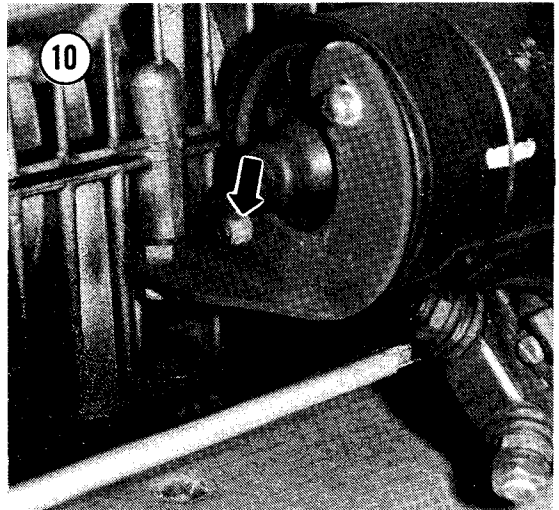
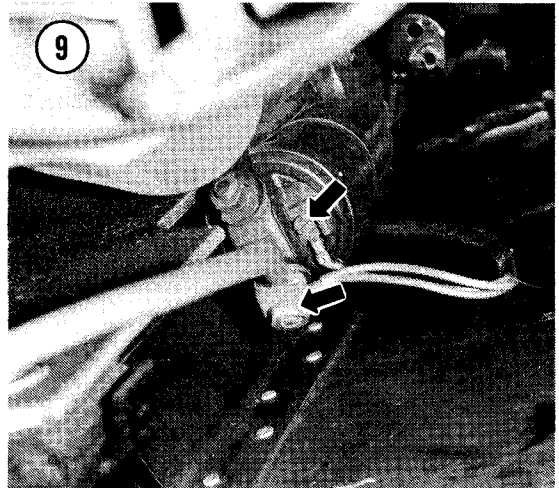

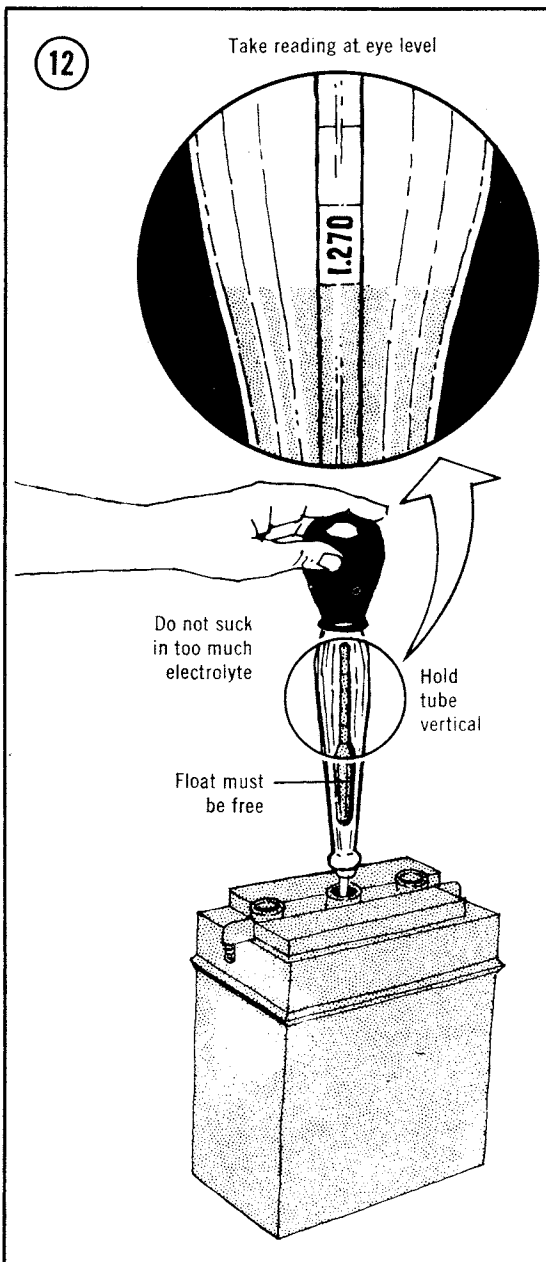

In freezing weather, never add water to a battery unless the machine will be operated for a period of time to mix electrolyte and water.

CAUTION

Keep battery fully charged. A discharged battery will freeze causing the battery case to break.

Remove the battery from the machine during extended non-use periods and keep battery fully

charged. Perform periodic specific gravity tests with a hydrometer to determine the level of charge and how long charge stays up before it starts to deteriorate.

Battery Specific Gravity Test

Determine the state of charge of the battery with a hydrometer. To use this instrument, place the suction tube (Figure 12) into the filler opening and draw in just enough electrolyte to lift the float. Hold the instrument in a vertical position and take the reading at eye level.

Specific gravity of electrolyte varies with temperature, so it is necessary to apply a temperature correction to the reading you obtain. For each 10° that the battery temperature exceeds 80°F, add 0.004 to the indicated specific gravity. Subtract 0.004 from the indicated value for each 10° that the battery temperature is below 80°F.

WARNING

Do not smoke or permit any open flame in any area where batteries are being charged. Highly explosive hydrogen gas is formed during the charging process.

The specific gravity of a fully charged battery is 1.260. If the specific gravity is below 1.220, recharge the battery (Figure 13).

Starter Test

If starter fails to crank engine or cranks engine very slowly, perform the following:

1. Inspect cranking circuit wiring for loose or badly corroded connections or damaged wiring.
2. Perform *Battery Specific Gravity Test* to be certain battery is charged and not defective.
3. Crank engine with recoil starter to make sure engine turns freely and is not seized.

NOTE: Remove spark plug wires. The following bypasses the ignition switch.

4. If starter still will not crank engine, place a heavy jumper lead from positive (+) battery terminal directly to starter terminal (Figure 14). This bypasses ignition switch and starter solenoid. If starter motor operates, then one of these items is defective. If starter motor will not operate, starter is defective.

Starter Solenoid Test

1. The starter solenoid is a sealed magnetic switch and cannot be repaired. If defective, it must be replaced.
2. Remove and insulate cable from starter terminal. Connect test light across 2 large terminals of starter solenoid.
3. With a jumper lead, connect positive (+) battery post to small terminal on solenoid. Solenoid plunger should snap in, light the test lamp, and hold until the jumper is removed. If not, solenoid is defective.

Rectifier Test

1. Disconnect 4 connectors from rectifier. A diode exists between each of the 4 terminals in the rectifier. Test the 4 diodes one at a time by connecting a test light to 2 adjacent terminals.
2. Test with leads on 2 top terminals, 2 bottom terminals, 2 left terminals, and 2 right terminals. Reverse terminal contacts in each test set-

- up. Do not test terminals in a diagonal pattern.
3. With leads connected one way, test light should light. With leads reversed, a high resistance or open condition should be indicated. Repeat test for the other 3 diodes. Replace if defective.

